

# DILLON



Dillon was founded in 1937 by William C. Dillon in the USA as a supplier of cable tensioning products to the armed forces. The company grew rapidly, expanded its offering and today has a comprehensive range of force measurement devices.

These products are sold into a wide variety of markets worldwide including lifting applications, telecommunications, aviation, military, public utilities, offshore oil/gas, shipping and lift maintenance.

In 1986, Dillon was acquired by Avery Weigh-Tronix, a world leading manufacturer of industrial scales, weighing equipment and measurement devices. Avery Weigh-Tronix is part of Illinois Tool Works (NYSE: ITW), a Fortune 200 diversified manufacturer of advanced industrial technologies with operations in 57 countries.

With a reputation for superior strength, reliability, accuracy and quality, Dillon goes from strength to strength.

## Contents

<b>3-15</b>	Dynamometers
<b>16-18</b>	Tension Meters/Tension Monitors
<b>19</b>	Indicator
<b>20-26</b>	Mechanical Force Gauges
<b>27-31</b>	Force Control Switches



# Dillon Information

## Common Conversions

FORCE	Description	Abbreviation	Conversions
	Newton	N	1 N = 0.2248 lbf = 0.1020 kgf
	kilogram-force or kilogram ("force" is dropped & implied)	kgf or kg	1 kgf = 1 kg = 9.807 N = 2.204 lbf
	pound-force or pound	lbf or lb	1 lbf = 1 lb = 4.448 N = 0.4536 kgf
	thousand pounds	kip	1 kip = 1000 lbf
MASS	Description	Abbreviation	Conversions
	short ton	ton	1 ton = 2000 lb
	long ton	long ton	1 long ton = 2240 lb
	metric ton	ton, tonn or tonne	1 metric ton = 1000 kg
TORQUE	Description	Abbreviation	Conversions
	Newton-meter	N*m	1 N*m = 0.102 kg*m = 0.738 ft*lb
	kilogram-meter	kg*m	1 kg*m = 9.807
	foot-pound or pound-foot	ft*lb or lb*ft	1 ft*lb = 1 lb*ft = 1.356 N*m
	inch-pound or pound-inch	in*lb or lb*in	12 in*lb = 12 lb*in = 1 ft*lb

## Key Terms

### Accuracy

1. The closeness of a measurement to a standard or a true value.
2. The predicted closeness of an instrument for a given measurement in good measuring conditions. % full scale accuracy is the largest expected error throughout the range from zero to rated capacity.  
Example:  $\pm 0.5\%$  full scale accuracy on a 10,000 kg dynamometer =  $0.5\% * 10,000 \text{ kg} = 50 \text{ kg}$  potential error (low or high).

### Calibration

The process which assigns display readings under known and controlled conditions and then verifies correctness of the assignment.

### Capacity

The rating or working limit of the instrument.

### Compression

A force pushing equally from two directions in the same axis.



### Divisions

The size of the increment when moving from one electronic digit (or mechanical marker) to the next. Almost always a multiple of 1, 2 or 5.  
Divisions = Capacity / Resolution

### Excitation

The voltage inputted to a load cell.

### Force

A push or pull that one body exerts on another. Some forces include gravity, spring, adhesion, friction, magnetic and impact.

### Full-scale capacity

See capacity.

### Load

Another term to describe force or torque.

### Recalibration

The process of comparing an instrument against a load standard and adjusting if readings are outside tolerance.

### Repeatability

The consistency of readings when a constant load is applied and removed multiple times.

**Reproducibility**

The consistency of readings with different operators when all other test conditions are the same.

**Resolution**

The number of increments between no load and full scale capacity. Resolution = Capacity / Divisions.

**Shackle**

The common forged hardware bow and pin connected to a dynamometer.

**Signal**

The voltage output of a load cell.

**Torque**

A force applied a distance away from an axis of rotation. Torque = Force \* Distance.

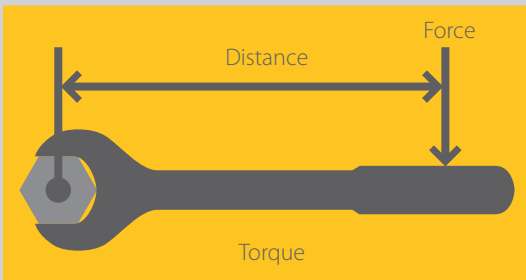

**Tension**

1. A force pulling equally from two directions in the same axis.
2. The tensile force in a wire.

**Ultimate Safety Factor**

The amount an instrument may be overloaded without physical separation of the load supporting elements. Expression examples: 5:1 or 500%, both mean five times the instrument capacity.

**Zero**

The reference point at which measurement starts. Loads above this point will be positive and loads below this will be negative.



**Recalibration Intervals**

Generally customers place Dillon force measurement instruments on a 12-month recalibration interval. However, the time period between calibrations may be shorter or longer depending upon their use, accuracy needs and internal requirements.

The recalibration interval is appropriate if customers find adjustments made during recalibrations are near their internal limits for accuracy.

The interval can be extended if customers find the adjustments are small compared to their standards.

The interval should be shortened if the adjustments are significant compared to their standards.

Customers who do not conduct studies on recalibration intervals should follow the guidance of an experienced measurement distributor.

# Dynamometers

## Dynamometer

A dynamometer measures the tension force exerted between two points in any direction.

Dynamometers are used to ensure the correct tension in power lines, telephone lines, zip wires, elevators, median barriers and architectural construction. They are also used to measure weight or downwards force in aviation MRO applications, hoisting and lifting and for load testing – amongst other diverse applications.

Dynamometers are very simple to operate with features such as real time measurement, peak capture, peak store and zero function. Dependent on the model, functionality can be expanded to digital display, variable peak capture rate, on-board data logging and data export.

Dillon is the best-known and oldest manufacturer of dynamometers. All of our instruments are portable, factory pre-calibrated and ready to work straight from the box.

Only Dillon offers both mechanical and electronic dynamometers, with the widest assortment of styles and capacities in each variant. All dynamometers are factory calibrated and delivered with a calibration certificate.



# AP Dynamometer

Dynamometers



5" (125 mm)  
ABS plastic carry case



Optional  
10" (250 mm)  
Steel carry case



5" (125 mm) 30,000 lb (15,000 kg)  
Heavy-duty reinforced plywood crate



The AP Dynamometer was originally designed to measure the tension on telephone wires and has proven to have limitless versatility as a tension and weight measuring instrument.

It is used for such diverse jobs as suspended weighing; tensioning support cables for bridges or aerial work ways; adjusting tension on guy wires; load testing; field testing chain, rope and wire.

Dillon is the world leader in mechanical dynamometers with the largest installed population globally. The sturdy design, top grade components, full NIST traceability and premium coatings make it the standard in force measurement and able to stand the test of time in the most severe environments and applications.

Embraced by both the military and industrial markets across the globe, we are confident that the AP will work in the most demanding applications.

### Feature for feature — Dillon Dynamometer sets the standard.

- **Capacity** – 500 lb to 50,000 lb / 500 kg to 20,000 kg.
- **Accuracy** –  $\pm 0.5\%$  of full scale capacity for precise data.
- **Safety** – 5:1 ultimate safety factor for overload protection and long life
- **Environmental** – Wide temperature range for use in nearly any environment (-50 to 140°F / -45 to 60°C)
- **Approvals** – CE on all capacities excluding 30,000 lb and 50,000 lb; ASME b30.26 compliant on 20,000 lb (10,000 kg) and below
- No batteries required
- Choice of dial face sizes 5" or 10" for the best in portability or visibility
- Anti-parallax design allows accurate readings from any perspective
- Maximum hand retains peak load point and is easily reset
- Zero reset or Tare functionality
- High strength case resists heavy blows
- Generous shackle openings mate with most hooks and hardware
- High specification materials on all load components. Heat treated to tight tolerances
- Durable powder coat paint provides outstanding protection
- Offset load beam eases tension measurement

### Shipping and Storage

- 5" (125 mm) diameter AP Dynamometer includes a rugged ABS plastic carry case with die-cut foam inserts.
- Capacities of 30,000 lb (15,000 kg) and above are shipped in a heavy-duty reinforced plywood crate.
- An optional steel carry case is available for 10" (250 mm) diameter dynamometers up to 20,000 lb (10,000 kg) capacity.

### Options:

#### Zero positioning

The standard zero position is 9 o'clock for both the 5" and 10" dial sizes. Capacities up to 20,000 lb can be supplied with the zero at 12, 3 or 6. Photo shows a nonstandard position of 12 o'clock.



Zero positioning

# AP Dynamometer

## Pound Capacities

		5" (125 mm) Dial Size		
		Part Number	Capacity x Division	Ultimate Safety Factor
LOW		30006-0019	500 x 5	5:1
		30006-0027	1000 x 10	5:1
		30006-0035	2000 x 20	5:1
		30006-0043	4000 x 25	5:1
		30006-0050	5000 x 50	5:1
		30006-0076	8000 x 50	5:1
		30006-0084	10,000 x 100	5:1
MED		30006-0092	15,000 x 100	5:1
		30006-0100	20,000 x 200	5:1

## Kilogram Capacities

		5" (125 mm) Dial Size		
		Part Number	Capacity x Division	Ultimate Safety Factor
LOW		30006-0134	500 x 5	5:1
		30006-0159	1000 x 10	5:1
		30006-0126	2000 x 20	5:1
		30006-0167	4000 x 25	5:1
MED		30006-0118	10,000 x 100	5:1

		10" (250 mm) Dial Size		
		Part Number	Capacity x Division	Ultimate Safety Factor
LOW		30007-0026	1000 x 5	5:1
		30007-0034	2000 x 10	5:1
		30007-0059	5000 x 20	5:1
		30007-0083	10,000 x 50	5:1
MED		30007-0109	20,000 x 100	5:1
HIGH		30784-0017	30,000 x 200	5:1
		30784-0033	50,000 x 200*	3:1

\* Not CE approved.

		10" (250 mm) Dial Size		
		Part Number	Capacity x Division	Ultimate Safety Factor
LOW		30007-0158	1000 x 5	5:1
		30007-0125	2000 x 10	5:1
		30007-0174	5000 x 20	5:1
MED		30007-0117	10,000 x 50	5:1
HIGH		30784-0058	20,000 x 100	4:1

## Dynamometer Specifications

**Accuracy:** + 0.5% of capacity

**Temperature Range:** -50° to 140° F (-45° to 60° C)

**Ultimate Safety Factor:** See table on cover for minimum USF

**Construction:**

- Pressure bar—
  - High-grade E4340 alloy steel or 7075-T651 aluminum
- Shackles—
  - A4140 forged steel (machined from E4340 steel)
- Shackle pins—
  - Machined from E4340 steel or 300 m steel

**Case Housing:**

- 5" models are equipped with high strength composite plastic case.
- 10" models use cast aluminum enclosure.

**Corrosion Protection:** Pressure bar protected with durable powder coat paint. Shackles and pins are electroless nickel plated. All integral machining and fasteners are produced from non-corrosive materials or have suitable plating.

**Zero Control:** Zero up to 20% of capacity. Zeroed load must be considered as part of ultimate load

**Calibration:** Traceable to NIST

**Documentation:** Includes User's Guide and signed calibration certificate

**Carry Case/Crate:**

- Low/Med capacity 5" dial – includes plastic carry case
- Low/Med capacity 10" dial – optional steel carry case
- All high capacity – includes reinforced plywood crate

**Periodic Proof Loads:** Controlled 150% proof loads permitted annually

**Approval:** CE on all capacities excluding 50,000 lb;  
ASME b30.26 compliant on 20,000 lb (10,000 kg) and below

## Weights

5" (125 mm) Low and Med			
Net Weight lb (kg)	Shipping Weight lb (kg)	Shipping Weight lb (kg) (steel case)	Packaging Dimension In (mm)
9 (4)	15 (6.8)		16 x 11 x 7" (406 x 279 x 177 mm)
10" (250 mm) Low and Med			
10 (4.5)	16 (7.2)	26 (11.7)	14 x 14 x 7" (355 x 355 x 177 mm)
30,000 - 50,000 (20,000 kg) High			
64 (29)	98 (44)		37.5 x 13 x 10.5" (952 x 330 x 266 mm)



# AP Dynamometer

Low and Medium Capacities  
500-20,000 lb / 200-10,000 kg

Dimensions in inches (mm)  
Drawing scales differ between capacities  
Dimensions subject to manufacturer /supplier tolerances and  
are subject to change without notice.

Dynamometers

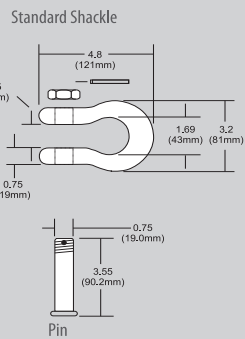
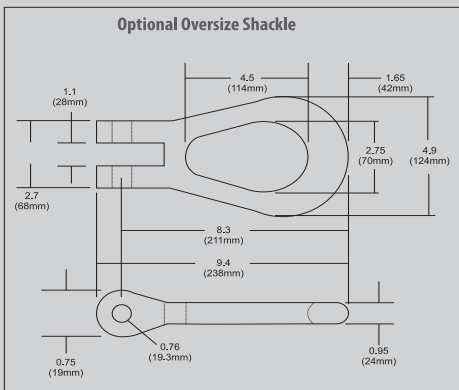
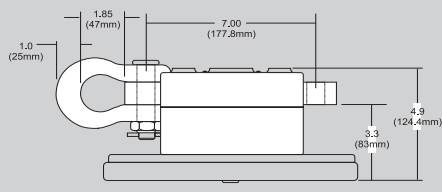
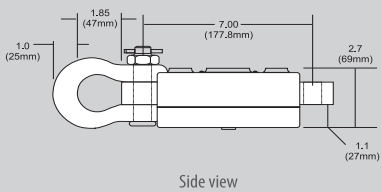
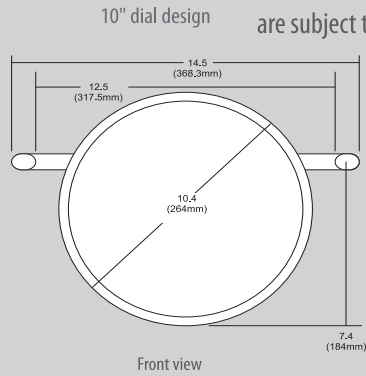
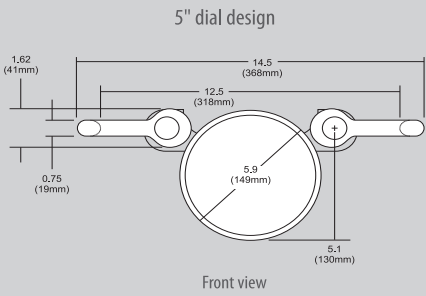

High Capacities  
30,000-50,000 lb / 15,000-20,000 kg

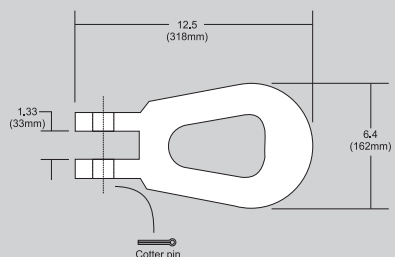
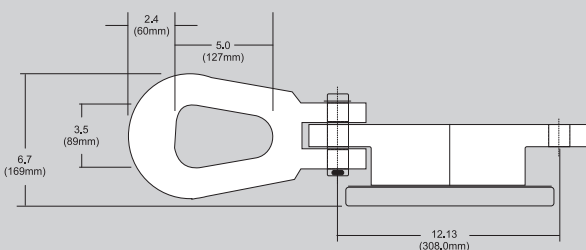
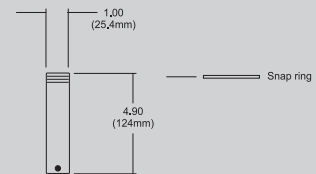
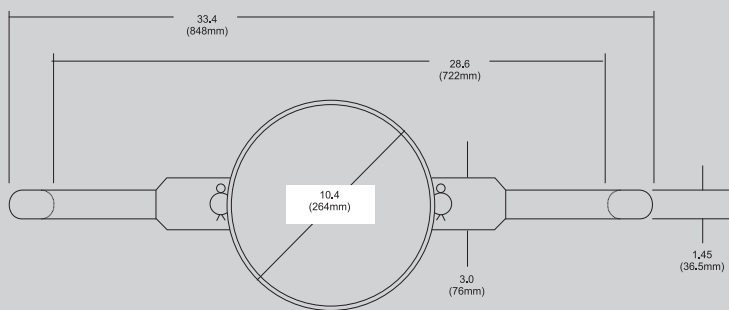

# EDXtreme Red Dynamometer



Guesswork is not acceptable – failure is not an option. When you have people working around high tension cables and massive loads, there is no room for error. Complete confidence in the strength and the accuracy of your measurement tools is a must.

Since 1937, Dillon Dynamometers have been chosen for the jobs where only the best will do. Now, Dillon has once again lifted the performance bar and set the standard for others to follow.

### Uncompromising and adaptable

The EDXtreme exemplifies the trademark precision and rugged construction of Dillon dynamometers. Its highly refined design draws on the inherent strengths of premium-grade materials to achieve a 5:1 minimum factor of safety.\*

While the EDXtreme may be configured for something as simple as a digital hanging scale, it offers a higher level of intelligence. With user-defined functions and sophisticated communication options, the EDXtreme readily adapts to multi-tasking operations or multi-link systems capable of monitoring a series of critical stress points from a single location - it is the definition of application versatility.

### Xtreme engineering

Building a precision instrument that can survive real-world punishment requires precise engineering. This is where Dillon's experience shines through. Our engineers have drawn upon their collective mechanical, electrical and component experience to achieve the highest structural integrity.

- **Capacity** – 250 lbf to 550,00 lbf / 1000 kgf to 250,000 kgf
- **7:1 factor of safety\*** – This measure of strength and safety is maintained by most capacities. Computer modeling confirms the low stress and long product life that is inherent in the EDXtreme design.  
*\* Models 5T and below feature a 7:1 safety factor. Models 10T- to 50T feature a 5:1 safety factor. Models 75T or higher feature a 4:1 safety factor.*
- **Superior strength and corrosion resistance** – High capacity models are constructed of powder coated aircraft-quality alloy steel. Lower capacity models are powder coated aircraft-quality aluminum.
- **Retained hardware** – Allows permanent attachment of centering spacers, which eliminates fumbling during high capacity rigging
- **NEMA 4X/IP68** – The EDXtreme is clearly the choice for reliability in any environment – in-plant or out on the job site
- **On board storage** (Accumulation lift and store, push button, and continuous)

### Xtreme accuracy

High resolution and accurate repeatable readings are essential to proper weighing. The higher standards set for the EDXtreme meant taking the time to ensure that material characteristics, load element design and strain gauge mesh perfectly. The result is a typical accuracy of 0.1% of full scale capacity\*. The enhanced resolution mode of 1 part in 5000 provides the level of readability needed for refined weighing.

### Xtreme ease

- **Exclusive SOFTKEY interface** – Dillon has eliminated confusing menus for faster setup and simple operation. In addition to lbf, kgf and Newtons, programmable functions can correct for gravitational variations and allow the use of custom units of measurement along with multiple lines or reeving.
- **Wide-angle, backlit LCD** – Provides improved readability over a wider viewing angle and has backlighting for low light conditions.
- **Battery operation** – The EDXtreme is powered by two standard C-cell batteries. Batteries are easily accessible for fast replacement.



# EDXtreme Red Dynamometer

Dynamometers



The EDXtreme can be upgraded for wireless use, enabling the dynamometer to connect to a handheld Communicator II which allows remote configuration, data acquisition and single point monitoring of multiple dynamometers.

Each EDXtreme has the choice of either a RS-232 or USB interface with data management software for real time logging. Additionally, the Communicator II comes with its own RS-232 interface.

### Typical Configurations

1. Standalone EDX for direct measurement applications.
2. Single network with one EDX radio dynamometer and Communicator.
3. Single network with multiple EDX dynamometers and one Communicator. The communicator monitors the load at each scale, plus the total weight.
4. Single network with two, three or four Communicators.
5. Multiple networks with multiple EDX dynamometers and Communicators.

### Communications unlock the full potential of the EDXtreme

The potential for additional functions is one of the a key reason for choosing an electronic dynamometer. Both the radio and hardwired options available within the EDXtreme range offer the convenience and safety of remote operation. Additionally, stored data can be downloaded to a PC via an RS-232 or USB connection for compilation and analysis or to generate hard copy printouts.

### Improved radio performance

The EDXtreme radio dynamometer uses leading-edge 2.4Ghz radio frequency technology to eliminate common interference issues. This spread spectrum technology will establish and maintain the strongest, most reliable communications within seconds and is plug and play.

### Dynamic monitoring and control

The optional Communicator II is an extremely powerful handheld remote that can define the function and manage the operation of one or more EDXtreme dynamometers using wired or radio technologies. Using the programmable SOFTKEY interface, one or more Communicator II devices can monitor multiple dynamometers within the same airspace. Using multiple-link lifting arrays, the Communicator II can display readings at any or all lift points and calculate the total load.

### Optional audible alarm

When safety and load monitoring are paramount, the optional audible alarm adds an extra level of protection. The alarm sounds when a pre-defi ned load limit has been exceeded, ideal for situations when the operator may not have sight of the screen.

### Options

Printer, remote display



CP103

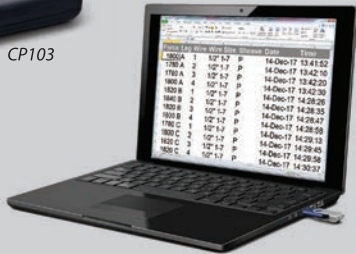

Rubber Sleeve



ABS plastic carry case



Plant airspace Discrete radio channel

Optional Remote Communicator II



# EDXtreme Red Dynamometer

## Capacity and Resolution

Model*	Capacity x Resolution (normal/enhanced)			Overload†	Construction
EDX-1T (EDX-2.5K)	2,500 lbf x 2/0.5	1,000 kgf x 1/0.2	10,000 N x 10/2	700%	Aircraft-quality 2024 aluminum
EDX-2T (EDX-5K)	5,000 lbf x 5/1	2,000 kgf x 2/0.5	20,000 N x 20/5		
EDX-5T (EDX-10K)	10,000 lbf x 10/2	5,000 kgf x 5/1	50,000 N x 50/10		
EDX-10T (EDX-25K)	25,000 lbf x 20/5	10,000 kgf x 10/2	100,000 N x 100/20	500%	Aircraft-quality E4340 alloy steel
EDX-25T (EDX-55K)	55,000 lbf x 50/10	25,000 kgf x 20/5	250,000 N x 200/50		
EDX-50T (EDX-100K)	100,000 lbf x 100/20	50,000 kgf x 50/10	500,000 N x 500/100		
EDX-75T (EDX-160K)	160,000 lbf x 100/50	75,000 kgf x 50/20	—	400%	Aircraft-quality E4340 alloy steel
EDX-100T (EDX-220K)	220,000 lbf x 200/50	100,000 kgf x 100/20	—		
EDX-150T (EDX-330K)	330,000 lbf x 200/100	150,000 kgf x 100/50	—		
EDX-250T (EDX-550K)	550,000 lbf x 500/200	250,000 kgf x 200/50	—		

\* Model number in parenthesis shows U.S. convention for describing capacities. † Ultimate overload protection rating.

## Dimensions inches (mm)

Model	A	B	C	D	E	F	G	H	J	Shackle
EDX-1T	10.6 (269)	5.0 (127)	7.8 (198)	1.06 (26)	0.75 (19)	15.3 (389)	13.4 (340)	1.36 (34)	1.69 (43)	Dillon
EDX-2T	10.6 (269)	5.0 (127)	7.8 (198)	1.06 (26)	0.75 (19)	15.3 (389)	13.4 (340)	1.36 (34)	1.69 (43)	Dillon
EDX-5T	11.4 (289)	5.3 (135)	8.1 (206)	1.46 (37)	1.00 (25)	17.5 (400)	15.7 (400)	2.17 (56)	2.28 (58)	Green Pin*
EDX-10T	11.5 (291)	5.3 (133)	7.9 (201)	2.01 (51)	1.38 (35)	21.0 (534)	18.5 (470)	3.50 (89)	3.25 (83)	Green Pin*
EDX-25T	13.7 (348)	6.0 (152)	9.0 (229)	2.91 (74)	1.97 (50)	28.7 (730)	25.2 (640)	5.70 (146)	4.96 (126)	Green Pin*
EDX-50T	15.8 (400)	6.8 (172)	10.3 (262)	4.13 (105)	2.75 (70)	38.8 (986)	33.7 (856)	8.98 (228)	7.09 (180)	Green Pin*
EDX-75T	16.5 (419)	7.8 (197)	10.3 (262)	4.13 (105)	2.75 (70)	39.3 (998)	33.7 (856)	8.58 (218)	7.09 (180)	Green Pin*
EDX-100T	18.0 (457)	7.8 (197)	11.0 (280)	5.00 (127)	3.25 (83)	46.9 (1911)	40.4 (1025)	11.14 (283)	7.48 (190)	Green Pin*
EDX-150T	21.0 (533)	8.8 (222)	12.6 (321)	5.25 (133)	3.75 (95)	53.9 (1368)	45.6 (1159)	12.3 (313)	9.0 (229)	Crosby
EDX-250T	27.0 (686)	9.8 (248)	17.5 (445)	8.5 (216)	5.00 (127)	75.8 (1925)	62.8 (1595)	17.9 (454)	13.0 (330)	Crosby

\*Dimensions shown using Green Pin shackles. Crosby shackles available. Consult factory for dimensions.

Dimensions shown are nominal and subject to tolerances.

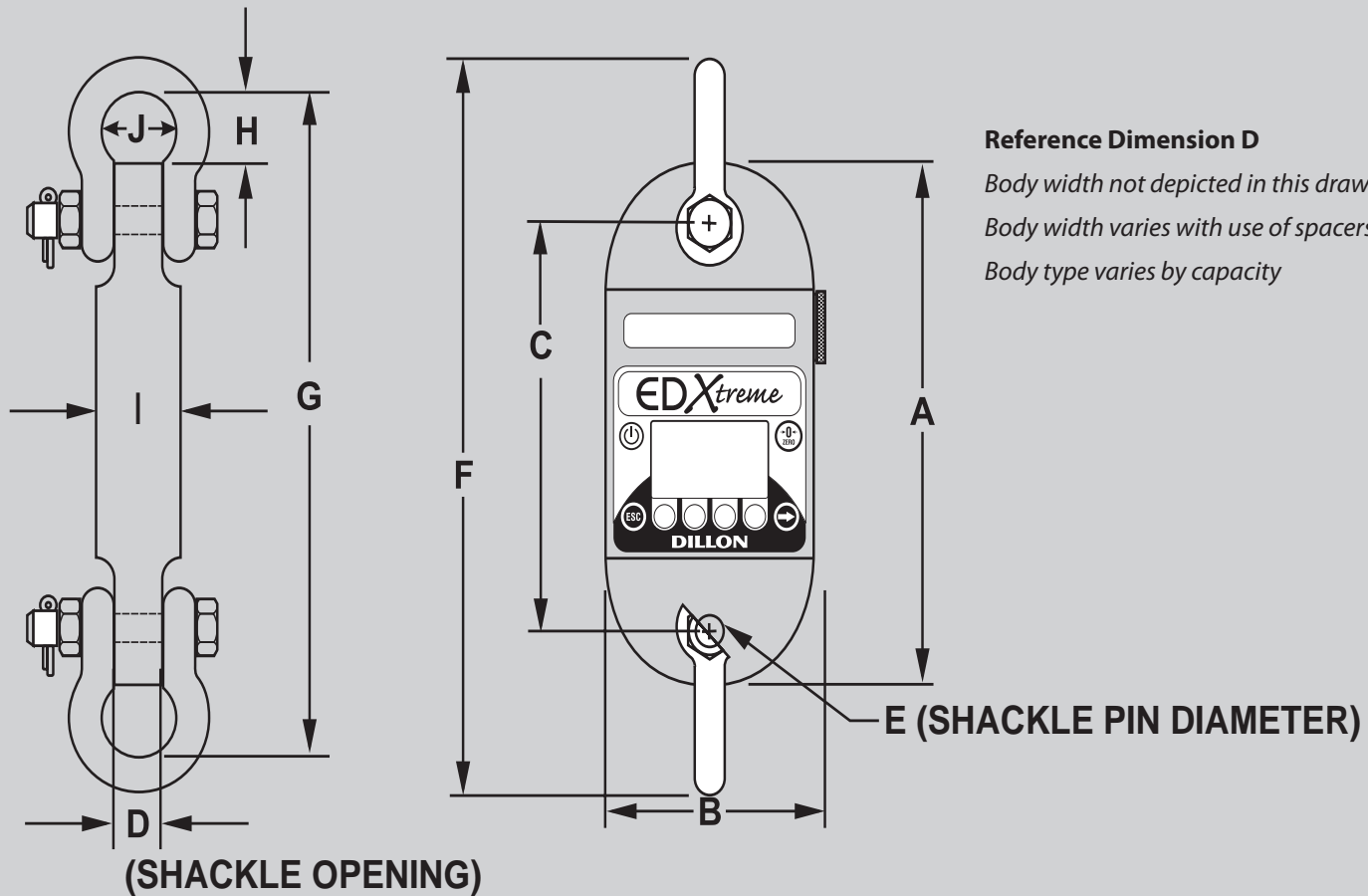

# EDXtreme Red Dynamometer

## Dynamometer Specifications

- Enclosure:** Designed to NEMA4X/IP68. Suitable for continuous outdoor use.
- Accuracy:** 0.1% of capacity up to EDX-50T.\*  
0.3% of capacity for EDX-75T and above.\*
- Repeatability:** 0.1% of capacity up to EDX-50T.\*  
0.3% of capacity for EDX-75T and above.\*  
\* Normal resolution mode with Dillon provided shackles.
- Proof Load:** 150% of capacity up to EDX-75T  
110% of capacity EDX-100T and above.
- Ultimate Overload:** See table on reverse.
- Safe Overload:** 200% of capacity
- Body Protection:** Aluminum and alloy steel capacities are powder coated
- Bearings:** Unmatched repeatability attained by needle bearings in shackle pin holes up to EDX-5T. Shackle pin acts as inner race.
- Shackles:** Forged industry standard anchor shackles. Models up to EDX-5T use precision machined shackle pin. Higher capacities use bar stock pin.
- Display:** 128 x 64 dot-graphic LCD display shows up to six digits 1.0" (26 mm) high plus annunciators and softkeys. Digits are 0.11" (3 mm) thick for unmatched readability
- Display Update Rate:** Two times per second
- Peak Capture Rate:** 10/100/1,000 Hz
- Connector:** Recessed sealed connector may be used for serial communications or connection to a Communicator II remote
- Communication:** Choice of RS-232 and USB. Print or extract data easily. Continuous output can drive a scoreboard. Configurable poll character.
- Calibration:** Traceable to the National Institute of Standards and Technology. Certificate included with curve of readings.
- Battery Life:** Standalone EDXtreme with no radio and no backlight lasts up to 400+ hours continuous. 150 hours continuous with Radio Link System. Use with two C-Cell alkaline batteries. When using backlight, battery life will be reduced, depending on intensity.
- Operating Temperature:** -4° F to 158° F (-20° to 70° C)
- Included with Instrument:** All include certificate of calibration, manual and batteries. Plastic carry case included for EDX-1T to EDX-50T. Higher capacities include rugged plywood storage crate. Instruments with shackles include centering spacers (EDX-20T and up) and shackle storage crate (EDX-20T to EDX-75T). Display backlight.
- Options:** Shackles and radio communications
- Approval:** CE on all capacities excluding 550K

## Communicator II Specifications

- Enclosure:** Designed to NEMA 3 / IP54 with optional sleeve. Suitable for protected outdoor use.
- Instrument Size:** 9.5 x 5.0 x 2.5" (241 x 127 x 64 mm)
- Accuracy:** Not applicable. Only sends and receives digital information.
- Display:** 128 x 64 dot-graphic LCD display can show full readings up to five instruments
- Battery Life:** Up to 80 hours continuous radio using four AA alkaline batteries
- Operating Temperature:** -4° F to 158° F (-20° to 70° C)
- Connectors:** Sealed connectors may be used for serial communications and wired connection to an EDXtreme Dynamometer.
- RS-232 Communication:** Print or extract data easily. Continuous output can drive a scoreboard. Configurable poll character.
- Included with Remote:** Carry case and batteries
- Accessories:** Rubberized case protector sleeve.  
Remote wall mount bracket. Serial and remote cable assemblies.
- Optional Audible Alarm:** Alarm sounds (105dB) when pre-defined load limit has been exceeded.
- Approval:** CE

## Radio Specifications

- FCC Certified:** For unlicensed low power devices. No radio licensing or permits required for normal operation.\* (In the US and Canada. Check local ordinances in other countries.)
- Frequency:** ISM 2.4 GHz frequency band operates between 2.4 to 2.4835 GHz
- Output Level:** 10 mW (10 dBm)
- Display Update Rate:** One time per second
- Number of Links Remote Can Control:** Up to 250 addresses
- Configuration Address:** Automatic and configurable
- Antenna:** Integral antenna
- Range:** Open-air range up to 600 feet (200 m), line-of-sight. Indoor range dependent upon environment with 300 feet (100 m) common. Low power radio systems are dependent upon interference levels from other radio systems and environmental conditions. Radio devices are not suitable for all applications.

## Weights

Model	Unit Weight lb (kg)	Weight with Shackles lb (kg)	Unit Ship Weight lb (kg)	Unit/Shackle Ship Dimension in (mm)
Communicator	1.25 (.6)	—	5 (2)	13 x 9 x 19 (330 x 229 x 483)
EDX-1T	4.3 (2.0)	8.6 (3.9)	18 (8)	16 x 7 x 19 (406 x 178 x 483)
EDX-2T	4.4 (2.0)	8.7 (3.9)	18 (8)	16 x 7 x 19 (406 x 178 x 483)
EDX-5T	5.6 (2.5)	14 (6)	23 (10)	16 x 7 x 19 (406 x 178 x 483)
EDX-10T	16 (7.3)	38 (17)	53 (24)	21 x 11 x 23 (553 x 279 x 584)
Model	Unit Weight lb (kg)	Shackle Weight lb (kg)	Unit Ship Weight/Dimension lb (kg) / in (mm)	Shackle Ship Weight/Dimension lb (kg) / in (mm)
EDX-25T	25 (11)	91 (41)	37 (17)	85 (39)
			16 x 7 x 19 (406 x 178 x 483)	15 x 8 x 26 (381 x 203 x 660)
EDX-50T	38 (17)	216 (98)	52 (24)	250 (113)
			16 x 7 x 19 (406 x 178 x 483)	17 x 9 x 23 (432 x 229 x 483)
EDX-75T	54 (25)	229 (104)	82 (37)	250 (113)
			12 x 10 x 32 (305 x 254 x 813)	17 x 9 x 23 (432 x 229 x 483)
EDX-100T**	70 (32)	395 (179)	480 (218)	
EDX-150T**	120 (54)	650 (295)	750 (340)	
EDX-250T**	250 (113)	1,490 (675)	1600 (726)	

\*\*Ships on pallet

# EDXtreme Blue Dynamometer



The EDXtreme Blue is the latest Dillon dynamometer offering, allowing for wireless use through a Bluetooth® connection with an Android or iOS device. Utilization of the Dillon EDX free mobile app allows for remote monitoring, data logging and exporting, and remote configuration of the EDXtreme Blue dynamometer.

Unlike the EDXtreme Red, the EDXtreme Blue dynamometer does not have a functional RS-232 or USB interface and does not connect to a Communicator II device. However, when paired with a user's mobile device the Dillon EDX mobile app allows for direct exporting of captured logs in PDF or CSV formats.

## Easy, One-to-One Communication

The EDXtreme Blue mobile app allows for easy discovery and direct pairing to any EDXtreme Blue dynamometer within a 400' line-of-sight range. Simply power on the EDXtreme Blue dynamometer, open the free Dillon EDX mobile application and select "Add Bluetooth Device". All EDXtreme Blue dynamometers that are powered on within range will populate the mobile app allowing for fast, painless pairing with the device.

Dillon's softKey interface eliminates confusing menus for faster set-up and simple operation. In addition to lbf, kgf, and Newtons, programmable functions can correct for gravitational variations and allow the use of custom units of measurement. In addition to the ability to change these setup options via the softKeys, toggling of units and zeroing ability performable through the mobile application.

While the Dillon EDX mobile app will detect numerous devices, it will only pair with one dynamometer at a time. In order to monitor the load/force of multiple dynamometers on a given screen at one time, users must utilize an EDXtreme Red with Communicator II.

## Xtreme engineering

Building a precision instrument that can survive real-world punishment requires precise engineering. This is where Dillon's experience shines through. Our engineers have drawn upon their collective mechanical, electrical and component experience to achieve the highest structural integrity.

- **Capacity** – 2500 lbf to 25,000 lbf / 1000 kgf to 10,000 kgf
- **7:1 factor of safety\*** – This measure of strength and safety is maintained by most capacities. Computer modeling confirms the low stress and long product life that is inherent in the EDXtreme design.  
*\* Models 5T and below feature a 7:1 safety factory. Model 10T features a 5:1 safety factor.*
- **Superior strength and corrosion resistance** – High capacity models are constructed of powder coated aircraft-quality alloy steel. Lower capacity models are powder coated aircraft-quality aluminum.
- **Retained hardware** – Allows permanent attachment of centering spacers, which eliminates fumbling during high capacity rigging
- **NEMA 4X/IP68** – The EDXtreme is clearly the choice for reliability in any environment – in-plant or out on the job site

# EDXtreme Blue Dynamometer

## Dynamometer Specifications

- Enclosure:** IP68
- Accuracy:** 0.1% of capacity up to EDX-10T.\*
- Repeatability:** 0.1% of capacity up to EDX-10T.\*  
\*Normal resolution mode with Dillon provided shackles.
- Proof Load:** 150% of capacity up to EDX-10T on Load Link.  
Will proof load shackles upon request.
- Ultimate Overload:** See table on reverse.
- Safe Overload:** 200% of capacity.
- Body Protection:** Aluminum and alloy steel capacities are powder coated.
- Bearings:** Unmatched repeatability attained by needle bearings in shackle pin holes up to EDX-5T. Shackle pin acts as inner race.
- Shackles:** Forged industry standard anchor shackles.
- Display:** 128 x 64 dot-graphic LCD display shows up to 6 digits 1.0" (26 mm) high plus annunciators and softkeys. Digits are .11 inches (3 mm) thick for unmatched readability.
- Display Update Rate:** 2 times per second.
- Peak Capture Rate:** 10/100/1,000 Hz
- Calibration:** Traceable to the National Institute of Standards and Technology. Certificate included with curve of readings.
- Battery Life:** Stand up to 400+ hours. Use with two C-Cell alkaline batteries. (When using backlight, battery life will be reduced, depending on intensity.)
- Operating Temperature:** -4° F to 158° F (-20° to 70° C).
- Included with Instrument:** All include certificate of calibration, manual and batteries. Plastic carry case included.
- Options:** Shackles.
- Approval:** CE on all capacities.

## Bluetooth Specifications

- FCC Certified:** For unlicensed low power devices. No radio licensing or permits required for normal operation.\* (In the US and Canada. Check local ordinances in other countries.)
- Frequency:** 2.402 GHz to 2.480 GHz.
- Output Level:** 2.5 mW (4 dBm).
- Antenna:** Integral antenna.
- Range:** Open air range up to 400 feet, line-of-sight with device not on ground. Indoor range untested. Low power Bluetooth systems are dependent on environmental obstacles and interference from other devices. Bluetooth devices are not suitable for all applications.

## Weights

Model	Unit Weight lb (kg)	Weight with Shackles lb (kg)	Unit Ship Weight lb (kg)	Unit/Shackle Ship Dimension in (mm)
EDx-1T	4.3 (2.0)	8.6 (3.9)	18 (8)	16 x 7 x 19 (406 x 178 x 483)
EDx-2T	4.4 (2.0)	8.7 (3.9)	18 (8)	16 x 7 x 19 (406 x 178 x 483)
EDx-5T	5.6 (2.5)	14 (6)	23 (10)	16 x 7 x 19 (406 x 178 x 483)
EDx-10T	16 (7.3)	38 (17)	53 (24)	21 x 11 x 23 (553 x 279 x 584)



View Tension in Real Time

Dynamometers

# EDjunior Dynamometer



### Big on the basics

The EDjunior Dynamometer gets straight to the point – apply a load; take a reading. Its sleek design was created for industries desiring an extremely well-built instrument that can be relied on for simple, yet critical measurements of weight and force.

The EDjunior draws its strength from the exhaustive engineering that went into the design of the Dillon EDXtreme Dynamometer. Both share the same base of research and testing to match material characteristics and load cell technology, ensuring an exceptionally rugged instrument capable of consistently delivering accurate, repeatable measurements.

### Proof of performance

The EDjunior is all about value. Behind its simple design and easy operation, you will find the quality and performance not found elsewhere in the low price range. With the EDjunior, Dillon proves that economy can go hand-in-hand with accuracy, long service life and, most importantly, worker safety.

### Measurement capabilities

The EDjunior provides peak detection as well as sustained load readings. Selectable units of measure include lbf, kgf and Newtons.

**Capacity** – 2500 lbf to 25,000 lbf / 1000 kgf to 10,000 kgf

**Ultimate safety factor\*** – This measure of strength and safety is maintained by most capacities. Computer modeling confirms the low stress and long product life that is inherent in the EDjunior design.

**Accuracy** – The load element design and strain gauges chosen for the EDjunior produce an accuracy of 0.2 % (full scale). This level of precision offers flexibility for use in a broad range of applications.

**Resolution** – Readings are displayed with a resolution of 1 part in 1000 to ensure the level of readability required for critical lifting applications.

### Control interface

The exclusive Dillon SOFTKEY interface provides direct access to setup and display functions without the typical confusing menu structure. The six digit dot-matrix display features 1.0" (26 mm) high numerals for greater visibility.

### High strength, low weight

Heavy, cumbersome tools make tough jobs even harder. Through the use of aircraft quality materials, Dillon has made the EDjunior an easy-to-position, highly mobile instrument with exceptional strength. It offers an impressive factor of safety at all capacities.

Dillon's distinctive curve-body design further eliminates unnecessary weight and streamlines the unit to help prevent binding.

*\* Models 5T and below feature a 7:1 safety factor. Models 10T feature a 5:1 safety factor.*



ABS plastic carry case

# EDjunior Dynamometer

Dynamometers

## Capacity and Resolution

Model*	Capacity x Resolution (normal/enhanced)			Overload†	Construction
EDjr-1T (EDjr-2.5K)	2,500 lbf x 2	1,000 kgf x 1	10,000 N x 10	700%	Aircraft-quality 2024 aluminum
EDjr-2T (EDjr-5K)	5,000 lbf x 5	2,000 kgf x 2	20,000 N x 20		
EDjr-5T (EDjr-10K)	10,000 lbf x 10	5,000 kgf x 5	50,000 N x 50		
EDjr-10T (EDjr-25K)	25,000 lbf x 20	10,000 kgf x 10	100,000 N x 100	500%	Aircraft-quality E4340 alloy steel

\* Model number in parenthesis shows U.S. convention for describing capacities. † Ultimate overload protection rating.

## Dimensions inches (mm)

Model	A	B	C	D	E	F	G	H	I	J
EDjr-1T	8.4 (213)	5.0 (127)	6.98 (174)	0.75 (19)	0.50 (13)	11.6 (296)	10.8 (274)	1.20 (30)	2.03 (52)	1.16 (29)
EDjr-2T	10.6 (269)	5.0 (127)	7.8 (198)	1.06 (27)	0.75 (19)	14.8 (375)	13.4 (340)	1.41 (35)	2.94 (75)	1.69 (43)
EDjr-5T	11.4 (289)	5.3 (135)	8.1 (206)	1.38 (35)	1.00 (25)	17.8 (451)	15.8 (402)	2.22 (56)	4.03 (102)	2.28 (58)
EDjr-10T	11.5 (291)	5.3 (133)	7.9 (201)	1.97 (50)	1.38 (35)	21.6 (548)	18.8 (478)	3.67 (93)	4.53 (115)	3.25 (83)

Dimensions shown are nominal and subject to tolerances.

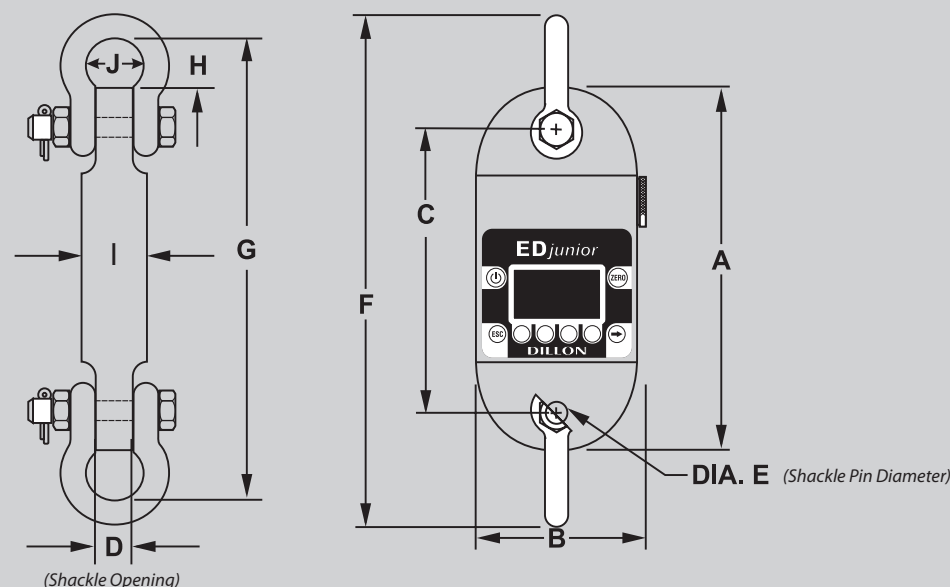

## Dynamometer Specifications

**Enclosure:** Designed to NEMA4X/IP68. Suitable for continuous outdoor use.

**Accuracy:** 0.2% of capacity

**Repeatability:** 0.2% of capacity

**Proof Load:** 150% of capacity

**Ultimate Overload:** See table above

**Safe Overload:** 200%

**Display:** 128 x 64 dot-graphic LCD display shows all digits 1.0" (26 mm) high plus annunciators and softkeys

**Display Update Rate:** Two times per second

**Peak Hold Sampling Rate:** Ten times per second typical

**RS-232 Communication:** Not available. See Dillon EDxtreme.

**Calibration:** Traceable to the National Institute of Standards and Technology. Calibration card included.

**Battery Life:** 425 hours typical use with two C-cell alkaline batteries

**Backlight: Configurable.** Using backlight will consume more battery power, reducing battery life

**Operating Temperature:** -4° F to 158° F (-20° to 70° C)

**Included with Instrument:** Carry case, batteries, manual and calibration card

**Overload:** Recorded at 120% with date and time stamp

## Weights

Model	Unit Weight lb (kg)	Ship Weight lb (kg)	Ship Dimension in (mm)
EDjr-1T (2500 lb)	3.9 (1.8)	13 (6)	19 x 16 x 7 (483 x 406 x 178)
EDjr-2T (5000 lb)	7.8 (3.9)	18 (8)	19 x 16 x 7 (483 x 406 x 178)
EDjr-5T (10,000 lb)	14.3 (6.5)	23 (10)	19 x 16 x 7 (483 x 406 x 178)
EDjr-10T (25,000 lb)	41 (19)	54 (24)	22 x 21 x 11 (559 x 533 x 279)

# EDjunior/EDxtreme Hardware Options

## Instrument and Hardware Dimensions

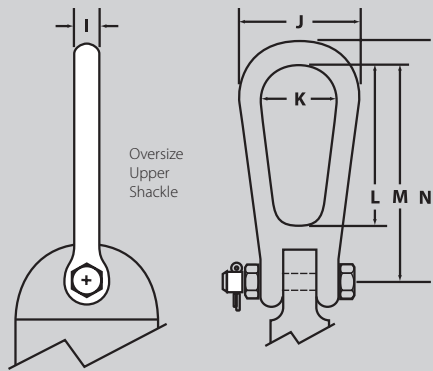
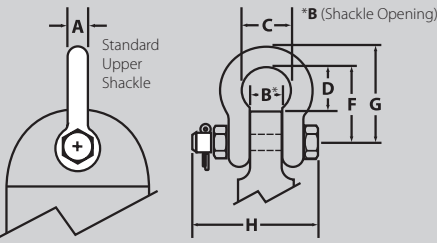

**EDxtreme Standard Upper Shackle**

Unit Capacity lb (kg)	A in (mm)	B in (mm)	C in (mm)	D in (mm)	F in (mm)	G in (mm)	H in (mm)	Weight lb (kg)
EDX-1T 2,500 (1000)	0.76 (19)	1.06 (26)	1.69 (42)	1.35 (34)	2.76 (70)	3.77 (96)	3.55 (90)	2.2 (1.0)
EDX-2T 5,000 (2000)	0.76 (19)	1.06 (26)	1.69 (42)	1.35 (34)	2.76 (70)	3.77 (96)	3.55 (90)	2.2 (1.0)
EDX-5T 10,000 (5000)	0.87 (22)	1.42 (36)	2.28 (57)	1.97 (50)	3.78 (96)	4.65 (118)	4.36 (110)	4.0 (1.8)
EDX-10T 25,000 (10000)	1.25 (32)	2.01 (51)	3.27 (83)	3.43 (87)	5.20 (132)	6.46 (164)	7.01 (178)	11 (5.0)
EDX25T 55,000 (25000)	1.75 (45)	2.91 (74)	4.96 (126)	5.66 (143)	8.00 (203)	9.76 (248)	9.80 (249)	32 (14.5)

**EDjunior Standard Upper Shackle**

Unit Capacity lb (kg)	A in (mm)	B in (mm)	C in (mm)	D in (mm)	F in (mm)	G in (mm)	H in (mm)	Weight lb (kg)
EDjr-1T 2,500 (1000)	0.43 (11)	0.75 (19)	1.16 (29)	1.18 (30)	1.94 (49)	2.39 (61)	2.64 (67)	0.5 (0.2)
EDjr-2T 5,000 (2000)	0.63 (16)	1.06 (27)	1.69 (42)	1.46 (37)	2.87 (73)	3.50 (89)	3.86 (98)	1.7 (0.8)
EDjr-5T 10,000 (5000)	0.87 (22)	1.42 (36)	2.28 (57)	2.13 (54)	3.78 (96)	4.65 (118)	5.12 (130)	4.0 (1.8)
EDjr-10T 25,000 (10000)	1.25 (32)	2.01 (51)	3.27 (83)	3.43 (87)	5.20 (132)	6.46 (164)	7.01 (178)	11 (5.0)

**EDxtreme Oversize Upper Shackle** - not available in 25,000 lb and 50,000 lb.

Unit Capacity lb (kg)	I in (mm)	J in (mm)	K in (mm)	L in (mm)	M in (mm)	N in (mm)	Weight lb (kg)
EDX-1T 2,500 (1000)	0.94 (24)	4.88 (124)	2.76 (70)	4.49 (114)	6.98 (177)	8.64 (219)	6.4 (2.9)
EDX-2T 5,000 (2000)	0.94 (24)	4.88 (124)	2.76 (70)	4.49 (114)	6.98 (177)	8.64 (219)	6.4 (2.9)
EDX-5T 10,000 (5000)	0.94 (24)	4.88 (124)	2.76 (70)	4.49 (114)	6.73 (171)	8.39 (213)	6.4 (2.9)

**EDjunior Oversize Upper Shackle** - not available in 2,500 lb.

Unit Capacity lb (kg)	I in (mm)	J in (mm)	K in (mm)	L in (mm)	M in (mm)	N in (mm)	Weight lb (kg)
EDjr-2T 5,000 (2000)	0.94 (24)	4.88 (124)	2.76 (70)	4.49 (114)	6.98 (177)	8.64 (219)	6.4 (2.9)
EDjr-5T 10,000 (5000)	0.94 (24)	4.88 (124)	2.76 (70)	4.49 (114)	6.73 (171)	8.39 (213)	6.4 (2.9)

**EDxtreme Instrument Body**

Unit Capacity lb (kg)	O in (mm)	P in (mm)	Weight lb (kg)
EDX-1T 2,500 (1000)	7.79 (198)	5.01 (128)	4.3 (2.0)
EDX-2T 5,000 (2000)	7.79 (198)	5.01 (128)	4.4 (2.0)
EDX-5T 10,000 (5000)	8.10 (206)	5.34 (136)	5.6 (2.5)
EDX-10T 25,000 (10000)	8.04 (204)	5.26 (134)	16 (7.3)
EDX-25T 50,000 (20000)	9.18 (233)	5.98 (152)	25 (11)

**EDjunior Instrument Body**

Unit Capacity lb (kg)	O in (mm)	P in (mm)	Weight lb (kg)
EDjr-1T 2,500 (1000)	6.89 (175)	4.98 (127)	2.9 (1.3)
EDjr-2T 5,000 (2000)	7.85 (199)	4.98 (127)	4.5 (2.0)
EDjr-5T 10,000 (5000)	8.17 (207)	5.34 (136)	6.4 (2.9)
EDjr-10T 25,000 (10000)	8.04 (204)	5.26 (134)	16 (7.3)

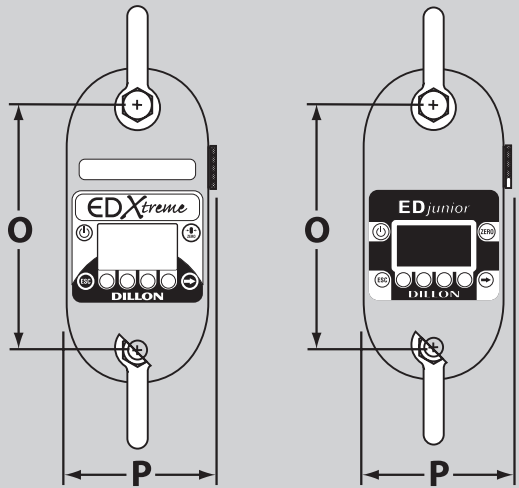

# Tension Meters / Tension Monitors

Tension Meters / Monitors

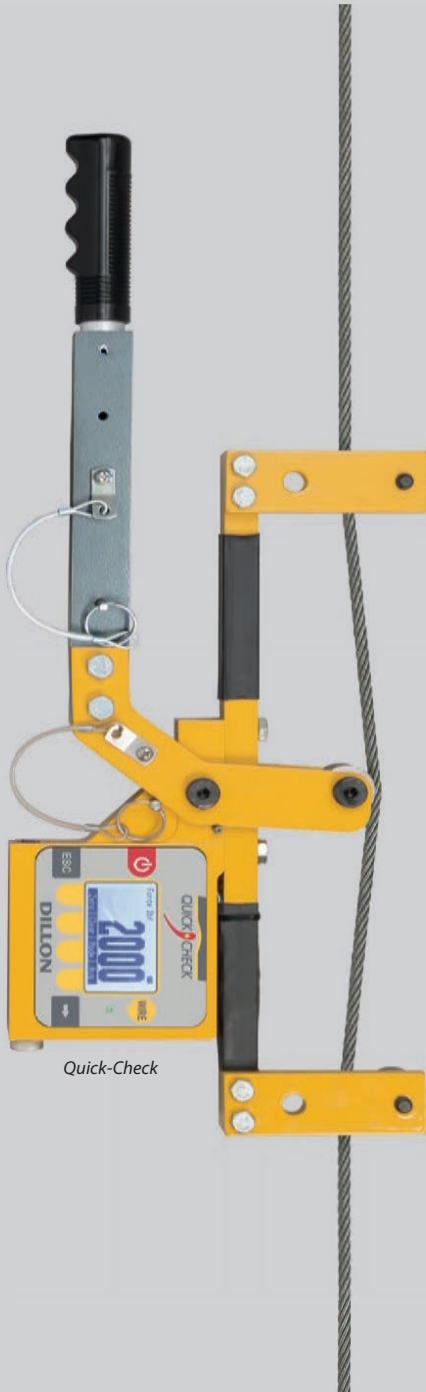

Quick-Check

## Tension Meter

Portable, fast and accurate.

This revolutionary new cable tension meter is robust and easy to use. The Dillon tension meter offers accurate tension readings within three seconds which can then be stored along with time and date for later analysis. This versatile design allows it to be used in a variety of applications from cell tower installation, zip lines and elevators to overhead high voltage power lines.

The Quick-Check tension meter is a must have for all installation, service and maintenance organizations as it can be used with a wide range of wire rope diameters and strand types ranging from 3/16" (4.75 mm) up to 1.0" (25.4 mm).

All units come with a Certificate of Calibration which is traceable to NIST, dated and signed by experienced technicians who calibrate each instrument on an individual basis, making certain that all parts are carefully adjusted and that every unit is within stated accuracy tolerances before it leaves the factory.



# Quick-Check Tension Meter



The Dillon Quick-Check Tension Meter is an unbelievably fast method of measuring tension in cell tower guy wires, cable guardrails, construction guy lines, railway power lines, zip lines, avalanche netting, rigging and circus apparatus and overhead wires.

The Quick-Check quickly clamps onto wires, measures and removes in seconds. The digital load cell is highly accurate and requires no lookup or correction tables. The operator can quickly select from 20 different wire calibrations stored in the Quick-Check's memory. The Check-Tensioning mode graphically displays the current and target tensions for extremely quick setting of line tension. Even the infrequent battery changes are quick. The Quick-Check has the added functionality of onboard memory, data export.

- Store wire rope readings and export data (ideal for tower data collection)
- Time saving check-tensioning mode
- Portable and rugged – designed for outdoor use
- Built-in averaging saves time and eliminates errors
- Factory calibrated for up to 20 unique wire sizes and types
- Sheaves with bearings eliminate friction and provide the best accuracy
- Accommodates a wide range of wire sizes and styles
- Telescoping handle engages meter quickly with minimal effort
- Highly visible yellow finish
- Easy-to-read display with full-text prompts
- RS-232 port
- Easy-to-use soft-key interface
- Uses popular AA batteries and has long life between changes
- Backlight configurable
- Onboard storage of wire rope readings

### Broad application

The Quick-Check can be employed in many industries to ensure proper tensioning. Typical applications include cell tower and stack guy wires, pretensioned cable barriers, bridges, railway power lines, fishing nets, winch rope, overhead electric transit wires, fall arrest systems, circus and acrobatic displays, avalanche and rock fall protection.



RS-232 port

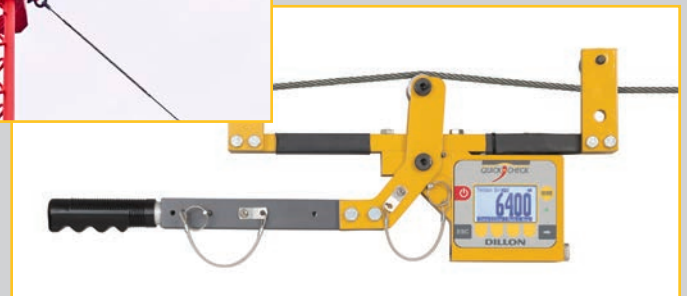

# Quick-Check Tension Meter

## Quick-Check Specifications

**Tension capacities:**

2000 lb/10 kN/1000 kg  
 10,000 lb/45 kN/4500 kg

**Wire sizes:** 3/16" (4.75 mm) up to 1.0" (25.4 mm)  
 View helpful ordering tips at [dillon-force.com](http://dillon-force.com)

**Accuracy:** + 3% instrument capacity (calibrated to specific wire size and type)

**Loading error:** Cable elongation of only 0.08" (2 mm)

**Display:** Dot-graphic LCD display supports full text and 1" high digits

**Time and date configurable**

**Sheave range:** Each set accommodates rated wire size and 1/2" smaller. Multiple sheave sets may be used.

**Suggested wire calibrations:** Calibrate each wire diameter needed with the most appropriate sheaves. If two wire types are used of the same diameter (e.g. 1/2" 1x7 and 1/2" 6x19), calibrate each type independently if accuracy is critical.

**Calibration:** Each wire rope calibration is traceable to the National Institute of Standards and Technology. Certificate included with curve readings. Passes only with three consecutive confirming runs, with all points in specification.

**Environment protection:** Suitable for continued outdoor use

**Battery life:** 120+ hours (backlight off)

**Operating range:** -4° F to 158° F (-20° C to 70° C)

**Tension units of measure:** pound-force, kilogram force, Newtons

**Resolution:** Configurable low/med/high

**Size:** 10 x 23 x 3" (25 x 59 x 8 cm)

**Weight:** Approx 11 lb (5 kg)

**Recalibration:** At user discretion. Commonly 12-24 months; should be more frequent with heavy use. On-site recalibration may be possible through your Dillon distributor.

**Approvals:** CE

Unit Weight lb (kg)	Unit Dimension in (cm)	Ship Weight lb (kg)	Ship Dimension in (cm)
11 (5)	9 x 24 x 3 (22 x 61 x 8)	27 (12)	28 x 16 x 8 (71 x 41 x 20)

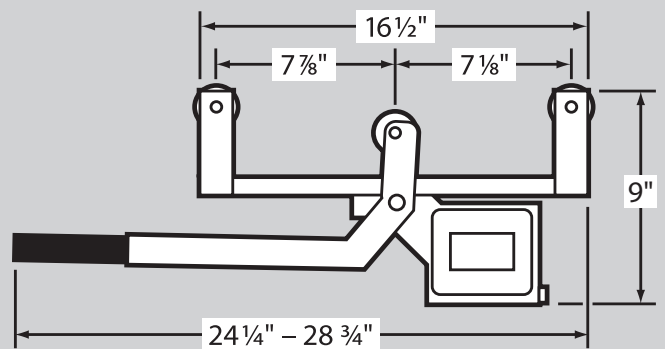

Tension Meters / Monitors



ABS plastic carry case



# FI-521 LED Load Cell Indicator



## Key Features:

- Three cell memory
- 80 Hz peak capture rate
- IP65
- Two RS-232 serial ports
- RS-485
- Five point curve linearization
- Built-in real time and date clock
- Units of measure: kgf, lbf, Newton
- Two set point outputs
- Seven pin load cell quick disconnect (equipped)
- Four remote keypad inputs
- Analog output

## Specifications

**Power supply:** Input 100 - 240 VAC, 50 - 60Hz internal mounted power supply with output of 12VDC at 2 amps

**Display:** Seven digits, seven segment, 0.7" (17 mm) ultra-bright LEDs with 14 annunciators. Max display range -999,999 to 999,999. Display update rate 10Hz.

**Keypad:** Six push buttons; select, cell, print, unit, zero, on/off

### Environment

**Working Temperature:** -10° C to 40° C (14° F to 104° F)

**Storage Temperature:** -20° C to 70° C (-4° F to 158° F)

**Humidity:** 10 to 90% RH without condensation

**Protection:** IP65

### Load Cell Drive Capacities

**Excitation Voltage:** 5VDC

**Capacity:** Drives up to eight 350-ohm load cells

**Signal Connection:** Four or six lead load cells

**Load Cell Input Range:** -15mV to +15mV

**Max Load Cell Output:** 3mV/V

### Communication

**Serial Port 1:** Full-duplex RS-232

**Serial Port 2:** Full-duplex RS-232 or half-duplex RS-485

**Baud Rate:** Selectable 1200-2400-4800-9600-19200/38400-57600 bps

**Data Output Format:** 8N1, 7O1, 7E1

**Serial Output:** Select up to 14 additional data parameters

**RS-485:** 0-5VDC

**Analog Output:** 0 to 2.5VDC ( $\leq 2.5\text{mA}$ )

**Remote Input:** Select, cell, print, unit, zero, off

**Setpoint 1 & 2:** 5 to 24VDC (.5A max) external, 5 to 8VDC ( $\leq .1\text{A}$ ) internal

The FI-521 is a bi-directional load cell instrument accepting both positive and negative load cell signals, internally performing the analog to digital conversion at 80 times per second. The FI-521 Indicator features an IP65 stainless steel enclosure for reliable performance in wet or dusty environments. Included swivel mounting bracket allows for wall or bench mounting. Watertight connections include the AC power cable, seven pin load cell quick disconnect cable connector and three additional cable ports. The instrument's six key front panel enables all setup, configuration and calibration procedures. FI-521's calibration procedures include a multi-point calibration feature for correcting the performance of non-linear load cells. The indicator has memory to store calibration information for up to three load cells.

The FI-521 can store peak and first peak values at 80 Hz. Operators can track stored data using date/time information and a six digit ID number. The stored data can then be printed or sent to a PC or other device using programmable print and data output formats. The FI-521's four logic level inputs and the bi-directional serial port can receive control commands from external devices. The instrument can control external devices via any of the two standard cutoff outputs. The FI-521 has an analog output that is fully calibrated for 0 to 2.5 VDC.



Combine several load cells together and see their total output with a load cell summing box

### Analog Circuit Characters

24-bit A/D converter

**A/D Conversion Speed:** Peak Force 80Hz; Live Force 10Hz

**A/D Conversion:** 1mV input will output 100,000 raw counts.

**Hardware:** low pass filter and two programmable digital low pass filters

**Max Display Range:** -999,999 to 999,999

**Division Number Range:** 100,000 divisions

**Real Clock:** Built-in nonvolatile real time & date

### Other Main Functions

Programmable zero range

Programmable automatic zero point tracking

Programmable motion detection window

Programmable auto-power off time

Adjustable LED brightness

**Units of Measure:** kgf, lbf, Newton

Configurable serial output content

Two set point output with two data comparison points

### Product Codes

AWT05-506170 - US Version

AWT05-506171 - EU Version

AWT05-506172 - UK Version

### Options

PCs, printers, remote displays

# Mechanical X Force Gauges



Model X-C



Model X-ST

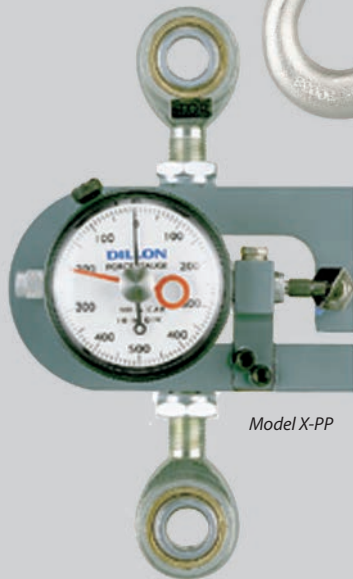

Model X-PP

## Options

- Shockless dial indicator for installations involving the sudden application or release of force. (Maximum pointer cannot be supplied with shockless dial indicator).

## Mechanical Force Gauge

The Dillon force gauge is an ultra-small instrument that displays the force exerted between two load points. Force gauges can measure tension, compression and push-pull. Gauges are available in tension, compression or both (push-pull) versions.

Proven accuracy and ruggedness sets our mechanical force gauge apart within the force measurement industry. The "D" shaped deflection beam is the heart of the force gauge system. We only use the best quality materials, machined to the narrowest tolerances and heat treated to provide the optimum strength and spring characteristics.

Mechanical force gauges are simple to operate with one main operating function, ZERO. Some models may be equipped with a maximum pointer to retain peak reading. These instruments are portable, factory precalibrated and ready to work out of the box. Includes calibration certificate.

The mechanical force gauges are ideal for standalone force applications or as the load defining component of a much larger system.

All units come with a Certificate of Calibration which is traceable to NIST, dated and signed by experienced technicians who calibrate each instrument on an individual basis, making certain that all parts are carefully adjusted and that every unit is within stated accuracy tolerances before it leaves the factory.

### Model X-C with compression calibration

Model X-C comes in nine capacities ranging from 50 lb to 25,000 lb or 50 to 10,000 kg. All feature an accuracy of  $\pm 1\%$  of full capacity, except the 25,000 (10,000 kg) capacity instruments which are accurate to  $\pm 2\%$  of full capacity.

Load is applied against a hardened ball which rotates to maintain vertical alignment as pressure increases. The ball is held in place with a spring clip or retainer. A threaded mounting hole is located opposite the loading ball in the bottom of the beam.

Model X-C is available in pound and kilogram capacities.

### Model X-ST with tension calibration

Dillon offers the Model X-ST in seven capacities from 100 lb to 10,000 lb or 25 kg to 5000 kg. Accuracy is  $\pm 1\%$  of full range. (Note: For applications requiring capacities beyond 10,000 lb or 5000 kg in tension, consider the Dillon Dynamometer).

Tension Force Gauges in capacities through 2,000 lb (1000 kg) are supplied with two rod-end connectors. 5,000 and 10,000 lb (5000 kg) capacities are equipped with convenient shackles and pins.

Calibration is available in pounds and kilograms.

### Model X-PP with compression/tension calibration

Force gauges calibrated in push-pull are available in four capacities in pounds ranging from 50-0-50 lb up to and including 2,500-0-2,500 lb and three metric capacities from 50-0-50 to 1000-0-1000 kg. Accuracy is  $\pm 2\%$  of maximum dial reading (based upon total capacity of both compression and tension scales).

Model X-PP gauges in capacities up to and including 500-0-500 lb or 250-0-250 kg are supplied with a set of self-aligning spherical rod-end connectors for tension loading. Force is applied to connectors through a hardened steel pin which must be slip fit in connector holes.

2,500-0-2,500 lb and 1000-0-1000 kg capacity gauges are equipped with two shackle adapters, shackles and pins. Shackles must be removed when compression load is involved. Force is then applied against shackle pins in a suitable test setup.

All push-pull gauges are supplied with a compression-loading spherical ball fitting for compression loading.

# Mechanical X Force Gauges

## Principle of operation

A D-shaped deflection beam is the heart of the Dillon Force Gauge. Machined to close tolerances, beams are heat treated to develop optimum strength and spring characteristics. High-strength aluminum is used in Model X instruments through 500 lb (200 kg). Ranges above this are fabricated from aircraft-quality alloy steel.

A precision dial indicator is mounted at the null point of the deflection beam. The indicator plunger rests against a slanted anvil at the open end of the beam, as shown in the photo. Under compression loads, the two halves of the beam tend to close. Tension force causes them to move apart. This action pushes the plunger inward, as determined by the slant of the anvil. Readings produced on the dial are in direct relation to applied load. The pointer revolves 360° clockwise under compression or tension forces. Push-pull gauges read half scale (180°) clockwise in compression, and counterclockwise, 180° from center zero under tension loads.

## Low beam deflection

When measured across the center of top- and bottom-loading holes, the approximate beam deflection is as follows:

50 to 250-lb capacity (25 to 100 kg)	0.019"
500-lb capacity (200 kg)	0.016"
1,000-lb capacity (500 kg)	0.018"
2,000-lb capacity (1000 kg)	0.011"
5- and 10,000-lb capacity (2 and 5000 kg)	0.010"

## Model X force gauge parts identification

1. Deflection beam
2. Dial indicator with zero at standard 12:00 position
3. Bezel
4. Maximum load pointer (optional)
5. Pressure button
6. Slanted anvil
7. Dial indicator plunger
8. Anvil set screw
9. Mounting bracket for dial indicator
10. Screws for mounting bracket
11. Bezel-locking screw
12. Loading ball
13. Spring retainer clip

## Overload rating

Accidental overloads up to 30% of capacity can be safely sustained without injury to the dial indicator or deflection beam. All capacities feature a 5:1 design safety factor.

## General information

- To reset zero, loosen knurled bezel-locking screw and rotate dial.
- Dillon Model X Force Gauges may be mounted horizontally, vertically, or flat.
- The baked-enamel finish resists corrosion and rust.
- Operating temperature up to 120° F (48° C).

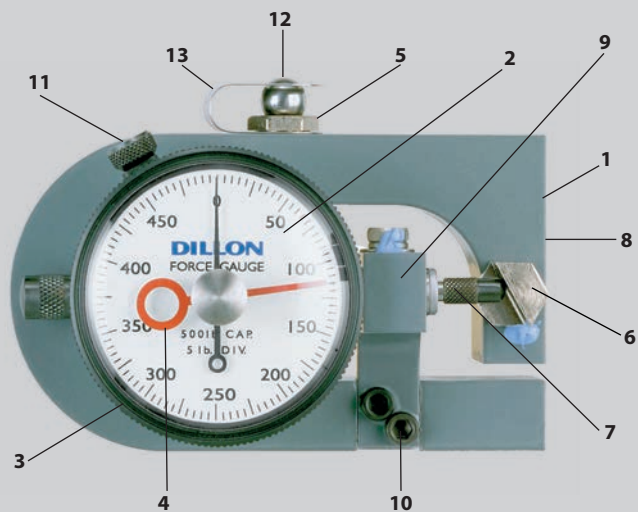

# Mechanical X Force Gauges

## Model X-C (Compression) Force Gauge

### A

Part Number	Pounds	Part Number	Kilograms	A in (mm)	B in (mm)	C in (mm)	D in (mm)	E in (mm)	F in (mm)	G in (mm)	H in (mm)	J in (mm)	J1 in (mm)	K in (mm)
30386-0035	50 x .05	-	-	4.25 (107.9)	1.00 (25.4)	0.50 (12.7)	2.50 (63.5)	2.06 (52.3)	2.00 (50.8)	2.25 (57.1)	0.38 (9.6)	1/4-28	1/4-28	2.94 (74.6)
30386-0043 30386-0159*	100 x 1	- 30386-0183*	50 x 0.5	4.25 (107.9)	1.00 (25.4)	0.50 (12.7)	2.50 (63.5)	2.06 (52.3)	2.00 (50.8)	2.25 (57.1)	0.38 (9.6)	1/4-28	1/4-28	2.94 (74.6)
30446-0033 30446-0090*	250 x 2.5	- 30446-0181*	100 x 1	4.25 (107.9)	1.00 (25.4)	0.50 (12.7)	2.50 (63.5)	2.06 (52.3)	2.00 (50.8)	2.25 (57.1)	0.38 (9.6)	1/4-28	1/4-28	2.94 (74.6)
30446-0017 30446-0074*	500 x 5	- 30446-0082*	200 x 2	4.25 (107.9)	1.00 (25.4)	0.50 (12.7)	2.50 (63.5)	2.06 (52.3)	2.00 (50.8)	2.25 (57.1)	0.38 (9.6)	1/4-28	1/4-28	2.94 (74.6)
30444-0019 30444-0050*	1,000 x 10	- 30444-0068*	500 x 5	4.25 (107.9)	1.00 (25.4)	0.50 (12.7)	2.50 (63.5)	2.06 (52.3)	2.00 (50.8)	2.25 (57.1)	0.38 (9.6)	1/2-20	1/2-20	2.94 (74.6)
30388-0017 30388-0058*	2,000 x 20	- 30388-0066*	1000 x 10	4.75 (120.6)	1.00 (25.4)	0.50 (12.7)	3.00 (76.1)	2.25 (57.1)	2.50 (63.5)	2.75 (69.8)	0.38 (9.6)	1/2-20	1/2-20	3.44 (87.3)
30389-0016 30389-0057*	5,000 x 50	- 30389-0065*	2000 x 20	4.75 (120.6)	1.00 (25.4)	0.50 (12.7)	3.00 (76.1)	2.25 (57.1)	2.50 (63.5)	2.7 (69.8)	0.38 (9.6)	1/2-20	1/2-20	3.44 (8.73)

### B

Part Number	Pounds	Part Number	Kilograms	A in (mm)	B in (mm)	C in (mm)	D in (mm)	E in (mm)	F in (mm)	G in (mm)	H in (mm)	J in (mm)	J1 in (mm)	K in (mm)
30423-0014 30423-0055*	10,000 x 100	- 30423-0063*	5000 x 50	5.87 (149.0)	1.87 (47.5)	0.94 (23.9)	3.94 (100.0)	2.75 (69.8)	3.00 (76.1)	3.62 (91.9)	0.75 (19.0)	7/8-14	7/8-14	4.50 (114.2)

## Model X-ST (Tension) and Model X-PP (Push-Pull) Gauges

### C

Part Number	Tension lb	Part Number	Tension kg	Part Number	Push-Pull lb	Part Number	Push-Pull kg	A in (mm)	B in (mm)	C in (mm)	D in (mm)	E in (mm)	F in (mm)
-	-	- 30443-0176*	25 x 0.25	-	-	-	-	4.25 (107.9)	1.00 (25.4)	0.50 (12.7)	2.50 (63.5)	2.06 (52.3)	2.03 (51.5)
30443-0044 30443-0150*	100 x 1	30443-0093 30443-0184*	50 x 0.5	30795-0014	50-0-50	-	-	4.25 (107.9)	1.00 (25.4)	0.50 (12.7)	2.50 (63.5)	2.06 (52.3)	2.03 (51.5)
30445-0034 30445-0109*	250 x 2.5	- 30445-0182*	100 x 1	30796-0013	125-0-125	30796-0021	50-0-50	4.25 (107.9)	1.00 (25.4)	0.50 (12.7)	2.50 (63.5)	2.06 (52.3)	2.03 (51.5)
30445-0018 30445-0083*	500 x 5	30445-0026 30445-0091*	200 x 2	-	-	-	-	4.25 (107.9)	1.00 (25.4)	0.50 (12.7)	2.50 (63.5)	2.06 (52.3)	2.03 (51.5)
30276-0012 30276-0053*	1,000 x 10	- 30276-0061*	500 x 5	30798-0011	500-0-500	30798-0029	250-0-250	4.25 (107.9)	1.00 (25.4)	0.50 (12.7)	2.50 (63.5)	2.06 (52.3)	2.03 (51.5)
30440-0013 30440-0054*	2,000 x 20	- 30440-0062*	1000 x 10	-	-	-	-	4.75 (120.6)	1.00 (25.4)	0.50 (12.7)	3.00 (76.1)	2.25 (57.1)	2.19 (55.6)

### D

- 30442-0052*	5,000 x 50	-	2000 x 20	30800-0017	2,500-0-2,500	30800-0025	1000-0-1000	4.75 (120.6)	1.50 (36.1)	0.75 (19.0)	3.00 (76.1)	2.25 (57.1)	2.66 (67.5)
- 30441-0053*	10,000 x 100	- 30441-0061*	5000 x 50	-	-	-	-	5.88 (149.2)	1.88 (47.7)	0.94 (23.9)	3.94 (100.0)	2.75 (69.8)	3.00 (76.1)

\*Max hand

# Mechanical X Force Gauges

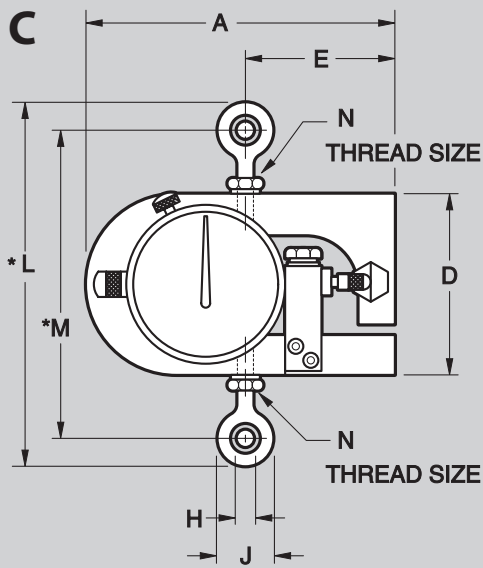
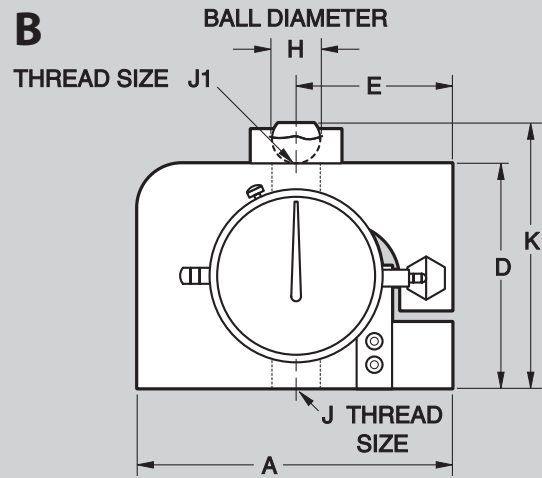
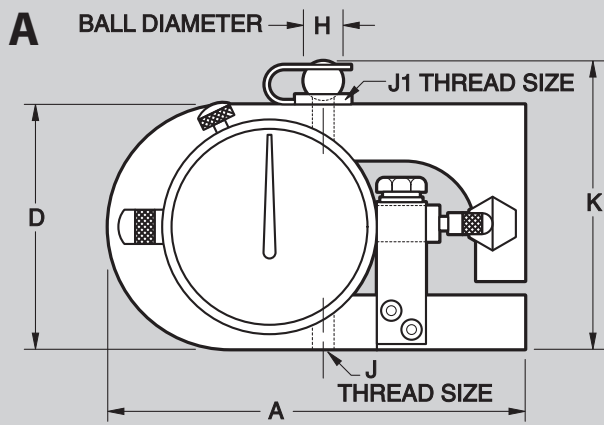

Top View of Drawings A,B,C

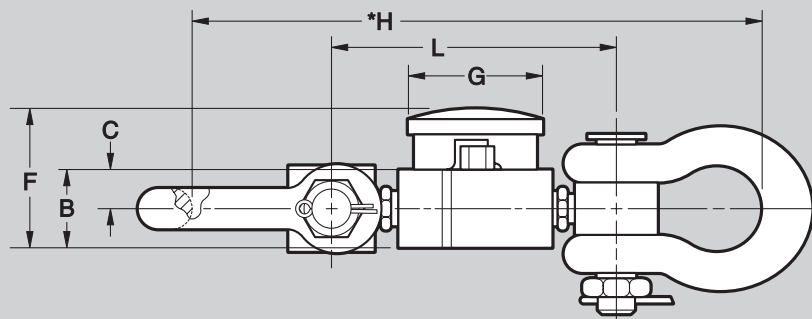
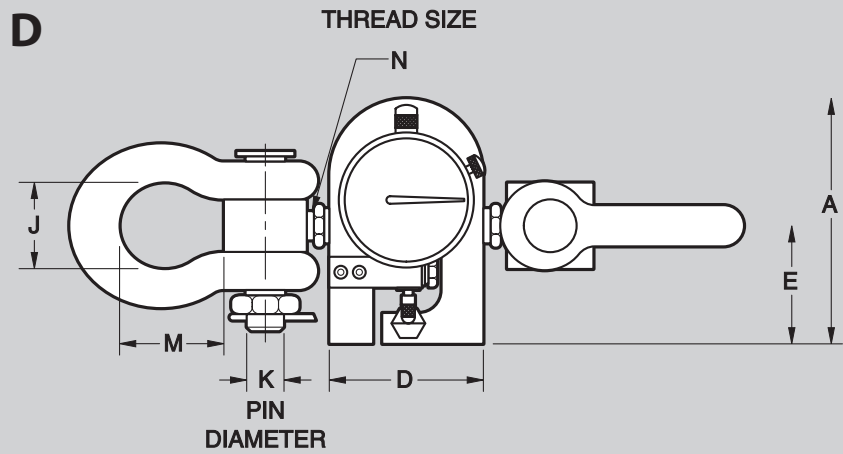
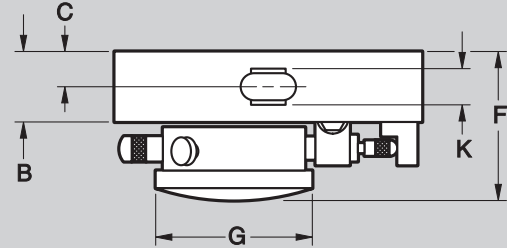

G in (mm)	H in (mm)	J in (mm)	K in (mm)	L in (mm)	M in (mm)	N in (mm)
2.25 (57.1)	0.25 (6.3)	0.75 (19.0)	0.38 (9.6)	5.00	4.25 (107.9)	1/4-28
2.25 (57.1)	0.25 (6.3)	0.75 (19.0)	0.38 (9.6)	5.00	4.25 (107.9)	1/4-28
2.25 (57.1)	0.25 (6.3)	0.75 (19.0)	0.38 (9.6)	5.00	4.25 (107.9)	1/4-28
2.25 (57.1)	0.25 (6.3)	0.75 (19.0)	0.38 (9.6)	5.00	4.25 (107.9)	1/4-28
2.25 (57.1)	0.50 (12.7)	1.31 (33.2)	0.62 (15.7)	6.94	5.62 (155.3)	1/2-20
2.75 (69.8)	0.50 (12.7)	1.31 (33.2)	0.62 (15.7)	7.44	6.12 (155.3)	1/2-20

2.75 (69.8)	10.94 (277.7)	1.69 (42.9)	0.75 (19.0)	5.44	1.94 (138.1)	1/2-20
3.62 (91.9)	12.69 (322.1)	1.69 (42.9)	0.75 (19.0)	7.19	1.94 (182.5)	7/8-1/4

# Mechanical U Force Gauges

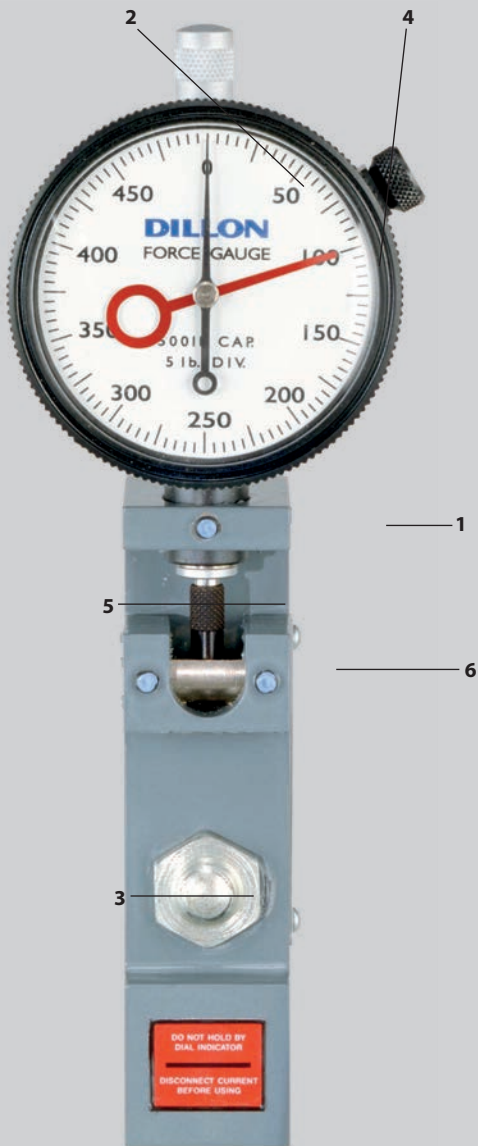

## Model U force gauge parts identification

1. Deflection beam
2. Indicator with zero at 6:00 position
3. Pressure fitting
4. Maximum pointer (optional)
5. Indicator plunger
6. Slanted anvil

## Model U Mechanical Force Gauges

The Model U Force Gauge is an accurate ( $\pm 1\%$  of full range) mechanical compression-measurement instrument. Its slimline design has repeatedly proven versatile in installations where space is at a premium.

The versatility of this simple instrument is demonstrated by the fact that it can be used as a hand-held device, permanently mounted on a flat surface plate, or used in test fixtures.

## How the U Force Gauge Works

The Dillon Model U Force Gauge employs a deflection beam machined from aircraft quality alloy steel and heat treated to develop optimum strength and spring characteristics. A precision dial indicator is mounted at the null point of this beam.

Compression force is normally applied against a single pressure fitting mounted on the upper half of the beam. (For accurate calibration, designate the type of pressure fitting you wish to use with the U Force Gauge. Dillon offers four fittings: domed, cupped, flat, or a flat nylon insert. Flat bottom gauges require only one fitting).

When load is exerted, the beam moves downward causing a slanted anvil on the free end to push against the indicator plunger. The indicator reading is a direct representation of the applied load.

## Dillon offers a capacity for every job

U Force Gauges are available for measurement in pounds or kilograms. There are 6-pound capacities ranging from 25 x .25 to 5,000 x 50 lb. The 4 kilogram capacities range from 10 x .1 to 500 x 5 kg.

Dillon also offers high-capacity gauges with pound capacities from 500 to 5000 lb and a metric model with a capacity of 500 kg. High-capacity gauges all have flat-bottom design, and each includes one pressure fitting of your choice.

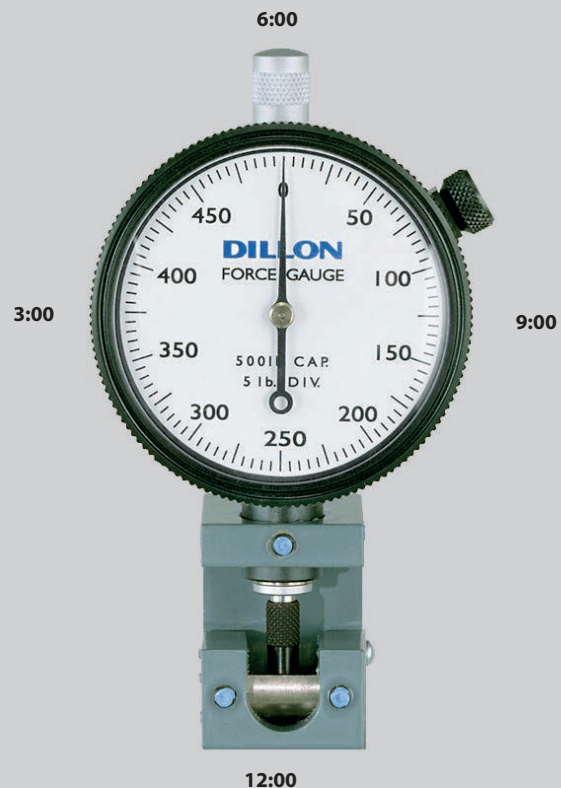

# Mechanical U Force Gauges

## Low-Range Flat-Bottom Model U Force Gauge

Part Number	Pounds	Part Number	Kilograms	A in (mm)	B in (mm)	C in (mm)	D in (mm)	E in (mm)	F in (mm)	G in (mm)	H in (mm)	J in (mm)	K in (mm)	L in (mm)	M in (mm)
30354-0017	25 x 0.25	30354-0066	10 x 0.1	3.28 (83.3)	5.50 (139.6)	0.73 (18.5)	0.36 (9.1)	0.97 (24.6)	0.56 (14.2)	0.90 (22.8)	1.40 (35.5)	1.87 (47.5)	0.46 (11.7)	0.094 (2.4)	1.67 (42.4)
30354-0033	100 x 1	30354-0082	50 x 0.5	3.28 (83.3)	5.50 (139.6)	0.73 (18.5)	0.36 (9.1)	0.97 (24.6)	0.56 (14.2)	0.90 (22.8)	1.40 (35.5)	1.87 (47.5)	0.46 (11.7)	0.094 (2.4)	1.67 (42.4)
30354-0058	250 x 2.5	30354-0090	100 x 1	3.28 (83.3)	5.50 (139.6)	0.73 (18.5)	0.36 (9.1)	0.97 (24.6)	0.56 (14.2)	0.90 (22.8)	1.40 (35.5)	1.87 (47.5)	0.46 (11.7)	0.094 (2.4)	1.67 (42.4)

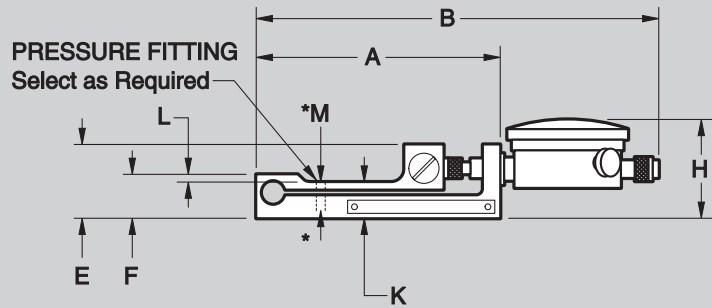
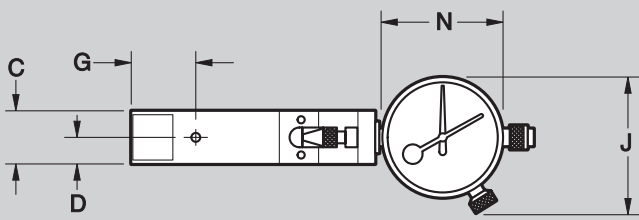

## High-Range Flat-Bottom Model U Force Gauge

Part Number	Pounds	Part Number	Kilograms	A in (mm)	B in (mm)	C in (mm)	D in (mm)	E in (mm)	F in (mm)	G in (mm)	H in (mm)	J in (mm)	N in (mm)
30482-0020	500 x 5	-	-	3.87 (98.0)	6.75 (171.3)	0.98 (24.9)	0.49 (12.4)	1.25 (31.5)	0.92 (23.6)	1.52 (38.6)	1.67 (42.4)	2.44 (63.5)	2.25 (57.2)
30482-0053	1,000 x 10	30482-0079	500 x 5	3.87 (98.0)	6.75 (171.3)	0.98 (24.9)	0.49 (12.4)	1.25 (31.5)	0.92 (23.6)	1.52 (38.6)	1.67 (42.4)	2.44 (63.5)	2.25 (57.2)
30478-0034	5,000 x 50	-	-	4.74 (120.1)	7.94 (201.5)	0.98 (24.9)	0.49 (12.4)	1.72 (43.7)	1.41 (35.5)	2.06 (52.3)	2.06 (52.3)	2.88 (72.8)	2.75 (69.9)

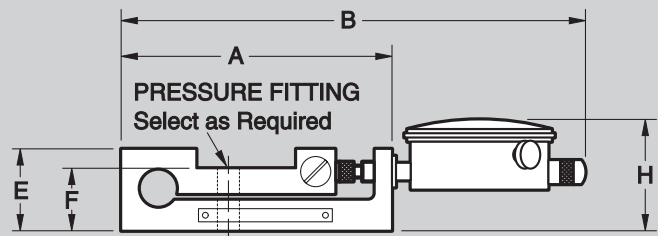
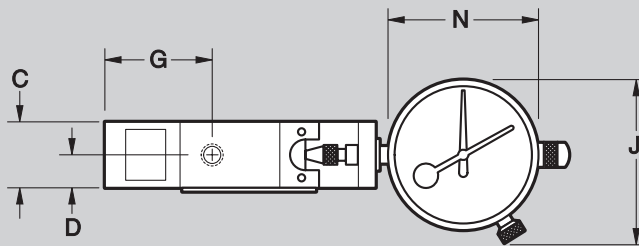

# Force Control Switches

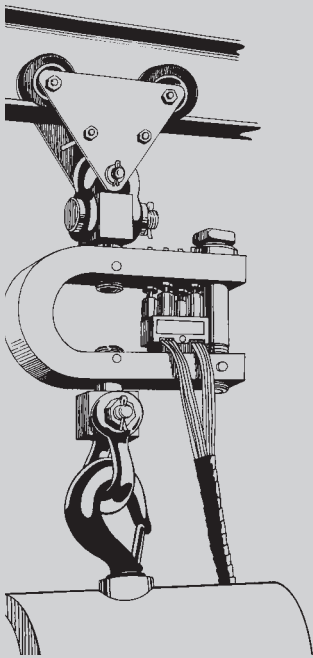

## DynaSwitch

One site for installation of a DynaSwitch is at the dead end of a line. If this is not practical, the DynaSwitch may be used to support an equalizer sheave, or an entire hoist may be suspended from the DynaSwitch.

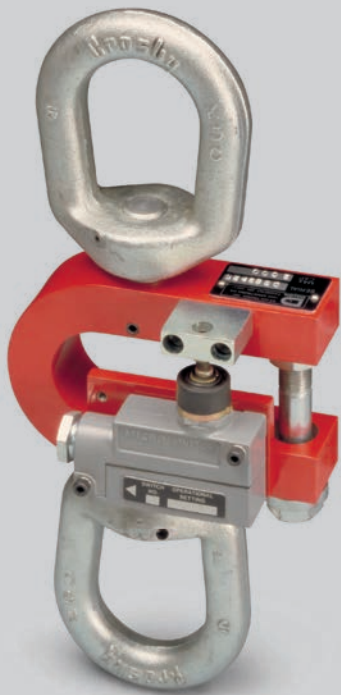

A device that provides switch outputs which change state (open/close) at specific forces. It requires no batteries or power to operate. Customers may connect these switches to a variety of devices such as relays, lights and alarms or to the motor controller to stop crane movement.

Common applications are:

- Overload protection
- Underload protection
- Desired force attainment (in repetitive operations such as a press)
- Batching

A force control switch may have multiple switches as needed for triggering at several loads. The switch settings are set at the factory to the specific load(s) desired by the customer. These set points are generally unchanged throughout its service life.

Force control switches are available in in-line or clamp-on versions. A calibration certificate is included.

Force control switches are used to protect cranes, hoists and other lifting machinery against weight or force overload as well as slack load. They are also used to perform control functions in the case of DynaSwitch. There are no dial indicators associated with these devices, only switches which not only shut off power when an overload condition exists, but also operate lights, buzzers or klaxons to warn of an impending overload.

# Force Control Switches - DynaSwitch



### For cable ends and supported loads

Dillon DynaSwitch systems are a reliable, low cost way to control forces and prevent overloads. They can be used in automation controls, acting as scales. They can be used on cranes, hoists and elevators - not only to shut off power when an overload condition exists, but also to operate lights, buzzers or klaxons to warn of an impending overload. Like 24-hour sentinels, they can operate in normal or extreme environments.

The heart of the system is a force beam which operates in tension or compression. Seven different load capacities are available. Switch and physical connection options are listed. Each beam can accommodate from one to four switches which can be set to operate as many as four different switching functions or combinations including slackline detection.

All DynaSwitch force beams and attachment fittings have an ultimate safety factor of 5:1 (4.5:1 for metric capacities). In addition, all models have an overload stop or bolt to provide extra protection to the measuring ability of the DynaSwitch force beam. Dillon will set the switches to trigger at the loads you desire, if specified at time of order.

## Specifications

	DSW-1	DSW-2	DSW-3	DSW-4	DSW-5	DSW-6	DSW-7
<b>Capacity lb (kg)</b>	100 (50)	1,000 (500)	2,000 (1000)	5,000 (2500)	10,000 (5000)	25,000 (12500)	50,000 (25000)
<b>Min Setpoint* lb (kg)</b>	15 (7.5)	100 (50)	200 (100)	500 (250)	1,000 (500)	1,250 (625)	2,500 (1250)
<b>Repeatability lb (kg)</b>	±3 (±1.5)	±30 (±15)	±60 (±30)	±150 (±75)	±300 (±150)	±750 (±375)	±1,500 (±750)
<b>Hardware options</b>	D,E,S	D,E,G,S	E,F,G,H,S	E,G,S	E,F,G,H,S	E,G,S	E,G
<b>Switch options</b>	A,J	A,J	B,C	A,J	B,C	B,C	B,C

## Dimensions

	DSW-1	DSW-2	DSW-3	DSW-4	DSW-5	DSW-6	DSW-7
<b>A in (cm)</b>	5.12 (13.0)	5.12 (13.0)	6.00 (15.2)	5.50 (14.0)	6.00 (15.2)	8.25 (21.0)	9.31 (23.7)
<b>B in (cm)</b>	2.94 (7.5)	2.94 (7.5)	3.50 (8.9)	3.00 (7.6)	3.50 (8.9)	5.00 (12.7)	5.00 (12.7)
<b>C in (cm)</b>	2.48 (6.3)	2.48 (6.3)	3.96 (10.1)	2.98 (7.6)	3.96 (10.1)	4.69 (11.9)	5.50 (14.0)
<b>D in (cm)</b>	0.98 (2.5)	0.98 (2.5)	1.47 (3.7)	0.98 (2.5)	1.44 (3.7)	2.38 (6.1)	2.68 (6.8)
<b>E in (cm) Option B</b>	n/a	n/a	1.59 (4.0)	n/a	1.59 (4.0)	1.59 (4.0)	1.59 (4.0)
<b>E in (cm) Option C</b>	n/a	n/a	2.48 (6.3)	n/a	2.48 (6.3)	2.48 (6.3)	2.48 (6.3)
<b>F (thread)</b>	¼ - 28 UNF	½ - 20 UNF	⅞ - 14 UNF	½ - 20 UNF	⅞ - 14 UNF	1¼ - 12 UNF	1¾ - 12 UNF

\*Multiply by 3 for Option C.

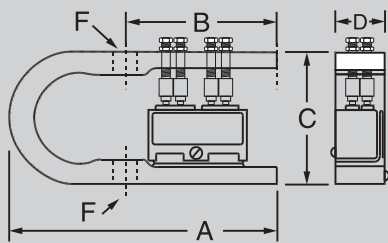

100 lb, 1,000 lb and 5,000 lb capacity force beam. Illustrated with four low differential switches.

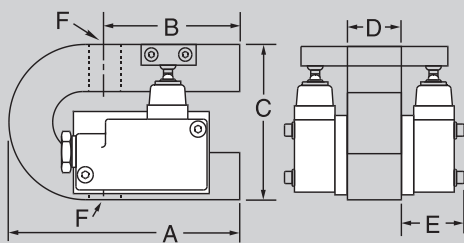

2,000 lb and 10,000 lb capacity force beam. Illustrated with two weatherproof switches (option 2B).

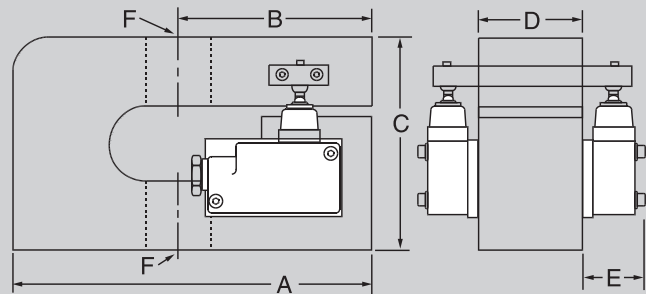

25,000 lb and 50,000 lb capacity force beam. Illustrated above two weatherproof switches (option B).

# Force Control Switches- DynaSwitch

## DynaSwitch Hardware Options

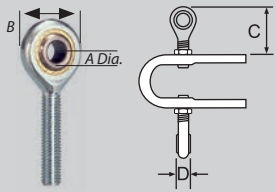

**Dimensions inches (cm)**

Model	A	B	C	D
DSW-1	0.25 (.64)	0.75 (1.9)	1.25 (3.2)	0.38 (1.0)
DSW-2	0.50 (1.27)	1.32 (3.4)	1.88 (4.8)	0.63 (1.6)

### Rod End Connectors for Tension Rigging

**FITS** DSW-1, DSW-2  
Self-aligning, rod end connectors are normally mounted at right angles to each other providing universal alignment under load. They can be mounted parallel to the force beam on request.



**Dimensions inches (cm)**

Model	A
DSW-1, DSW-2, DSW-4	0.45 (1.1)
DSW-3, DSW-5	0.61 (1.6)
DSW-6, DSW-7	0.83 (2.1)

### Hardened Ball and Cup for Compression Use

**FITS** All  
Heat-treated alloy steel. Cup is highly polished and plated. Ball is held in place by spring clip held by shoulder of cup. Slightly different configuration for high range switches.



**Dimensions inches (cm)**

Model and Switch	A
DSW-3	Switch B 4.34 (11.0)
	Switch C 5.24 (13.3)
DSW-5	Switch B 4.34 (11.0)
	Switch C 5.06 (12.9)

### Lifting Eye for Tension Use

**FITS** DSW-3, DSW-5  
Hardened steel eye threads into force beam. Oriented parallel to force beam unless otherwise specified. Orientation fixed by roll pin.

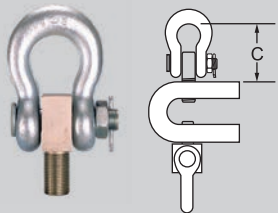

**Dimensions inches (cm)**

Model	DSW-2	DSW-3	DSW-4	DSW-5	DSW-6	DSW-7
A	1.69 (4.3)	1.69 (4.3)	1.69 (4.3)	1.69 (4.3)	3.25 (8.2)	5.00 (12.7)
B	1.94 (4.9)	1.94 (4.9)	1.94 (4.9)	1.94 (4.9)	4.06 (10.3)	6.12 (15.5)
C	4.19 (10.6)	4.13* (10.5)	4.19 (10.6)	4.13† (10.5)	7.12‡ (18.1)	10.36 (26.3)

### Adapter, Shackle and Pin

**FITS** All except DSW-1  
A hardened, forged steel shackle with adapter and pin for tension rigging of DynaSwitches. Shackles and similar fittings are installed at time of manufacture with the plane of the top fitting lifting opening parallel to the beam length, and at 90° to the position of bottom fitting. Orientation fixed by roll pin.

\* Option C switch is 4.76 inch (12.1 cm)  
† Option C switch is 5.06 inch (12.85 cm)  
‡ Option C switch is 8.38 inch (21.3 cm)

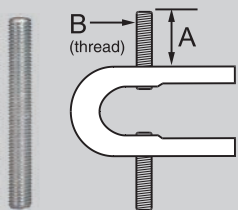

**Dimensions inches (cm)**

Model	DSW-1	DSW-2	DSW-3	DSW-4	DSW-5	DSW-6
A	1.25 (3.2)	1.88 (4.8)	2.19 (5.6)	2.31 (5.9)	2.19* (5.6)	2.31 (5.9)
B	¼-28	½-20	7/8-14	½-20	7/8-14	1¼-12

### Threaded Stud

**FITS** All except DSW-7  
For applications where conventional shackle or attachment eye cannot be used. Will accommodate yokes and other special fixtures. Heat treated alloy steel, secured by a roll pin.

\* Option C switch is 2.00 inch (5.1 cm)

# Warranty

## WARRANTY and SERVICE POLICY FORCE MEASUREMENT PRODUCTS

### Statement of Limited Warranty

Subject to the terms and conditions as stated herein, Avery Weigh-Tronix, LLC. (hereafter referred to as "Dillon") warrants its equipment to be free from defects in material and factory workmanship for a period of twenty-four months from the date of shipment, unless otherwise stated on sales literature.

### Terms and Conditions of Limited Warranty

This obligation is limited exclusively to defective original equipment manufactured or supplied by Dillon and is subject to the inspection and analysis by Dillon to conclusively identify or confirm the nature and cause of failure. Dillon is not responsible for the maintenance or calibration of its equipment beyond the date of shipment. Scheduled periodic maintenance, calibration checks and calibration adjustments are the responsibility of the equipment owner.

Equipment owner is responsible for equipment return to Dillon factory in packaging suitable for shipping rigors. Damage occurring to shipping related handling is not covered under warranty.

Defective components or parts will be replaced during the warranty period provided the failed item is returned to the factory. Labor will be waived on work associated with warranty repairs performed at the factory. Equipment will be shipped via ground/surface to the originating address at factory expense on equipment with factory warranty repair.

Dillon's responsibility is confined to the repair or replacement of Dillon equipment or parts and does not extend coverage to labor, material or service charges involved in removal of equipment for return to the factory.

Dillon is not responsible and will not be held liable for losses, injury or damage caused to persons or property by reason of the installation of Dillon products or their failure.

This warranty is not applicable for expenses, either direct or consequential, that may arise from the use or inability to use these products.

Dillon reserves the right to incorporate improvements in material and design of the products without notice and is not obligated to incorporate the same improvements in equipment previously manufactured.

In certain cases, such as used equipment or peripheral equipment not manufactured by Dillon, a reduced warranty may apply.

### Conditions Which Void Limited Warranty

This warranty shall not apply to equipment which:

- A. Has had repairs or modifications not authorized by Dillon which in Dillon's judgement have affected the performance or reliability.
- B. Has been subject to misuse, negligent handling, improper installation, extreme environmental conditions, accident, damage by fire, water, submersion, or act of God.
- C. Has had serial numbers altered, defaced or removed.

### Freight Carrier Damage

Claims for equipment damaged in transit must be referred to the freight carrier. Visible damage should be reported immediately. Concealed damage as soon as possible, in any case, within fifteen (15) days of receipt of shipment, in accordance with freight carrier regulations.

THE FOREGOING IS IN LIEU OF ALL OTHER WARRANTIES, EXPRESS OR IMPLIED INCLUDING ANY WARRANTY THAT EXTENDS BEYOND THE DESCRIPTION OF THE PRODUCT. This warranty statement sets forth the extent of our liability for breach of any warranty or deficiency in connection with the sale or use of the product. It is understood that we will not be liable for consequential damages of any nature, including but not limited to, loss of profit, delays or expenses, whether based on tort or contract.





# DILLON

## DILLON USA

1000 Armstrong Drive  
Fairmont, MN 56031

**Toll-Free:** (800) 368-2031

**Phone:** (507) 238-8796

**Fax:** (507) 238-8258

**Email:** [info@dillon-force.com](mailto:info@dillon-force.com)

[www.dillon-force.com](http://www.dillon-force.com)

Dillon is part of Avery Weigh-Tronix. Avery Weigh-Tronix is a trademark of the Illinois Tool Works group of companies whose ultimate parent company is Illinois Tool Works Inc ("Illinois Tool Works"). Copyright © 2026 Illinois Tool Works. All rights reserved. This publication is issued to provide outline information only and may not be regarded as a representation relating to the products or services concerned. This publication was correct at the time of going to print, however Avery Weigh-Tronix reserves the right to alter without notice the specification, design, price or conditions of supply of any product or service at any time.